

Modular 6kVA inverter system

Wall and floor standing installation
800 x 600x 490 mm (h x w x d)

OPUS INV 24-6.0 OC0864 F
OPUS INV 48/60-6.0 OC0864 F
OPUS INV 110/125-6.0 OC0864 F
OPUS INV 220-6.0 OC0864 F



Product Description

OPUS Inverter Systems are robust, free convection cooled, N+1 redundant DC to AC power conversion solutions for critical infrastructure applications such as transmission and distribution substations, process industries, railway signalling and substations and telecommunications.

OPUS Inverter Systems consist of inverter modules, static bypass, manual bypass and AC load distribution. System is configurable to meet the requirements of the application. On top of 2 relay alarms, system can be connected to OPUS VID1 controller and monitored via modern communication protocols such as Ethernet TCP/IP, Modbus TCP/IP, SCADA IEC61850, SNMP and RS-232.

OC0864 800x600x490mm standard cabinet systems deliver maximum 6kVA/6kW with static bypass and manual bypass. System supports typical battery voltages 24V, 48V, 60V, 110V, 125V and 220V. Output voltage is adjustable 200-240VAC 50-60Hz. As an option system can be equipped with two DC inputs A + B to support supply of double powered critical applications. Quantity of Inverter modules and load distribution fuses are configurable to match with requirements of the application.

Features

- Modularity, n+1 redundancy
- Configurable on-line/off-line default supply with bypass and manual bypass modules
- Efficiency on-line 90%, off-line >99%
- Full integration to OPUS DC power systems
- Convection cooling or redundant fans, air flow bottom to top fan
- Nominal Input voltages 24VDC, 48-60VDC, 110-125VDC, 220 VDC
- Flexible design with full front cabling
- Configurable load distribution
- Option: A+B double DC input
- Safety:
 - Cabinet: EN61439-1, EN61439-2
 - Inverters: EN 62368-1
- EMC:
 - Cabinet: EN61439-1, EN61439-2
 - Inverters: EN 61000-6-1 / -2 / -3 / -4

Technical Specifications

General construction	
Cooling, modules	1000VA modules natural convection 1200VA modules temp. controlled fan
Protection	IP 20, Option IP21
Cabling	Default top entry Option bottom entry
Colour	Frame RAL 7037, door RAL 7024
Dimensions & weight	Height 800mm (w/o feet) Width 600 mm Depth: 490 mm

Environment and standards	
Temp. range	-10°C ... +40°C, derated power up to +60 °C
Humidity max	95% relative humidity, non-condensing
Altitude	Max 3km, full power up to 2km above sea level Derating 2% per 100 m between 2-3km
Safety	Cabinet: EN61439-1, EN61439-2 Inverter & bypass modules: EN 62368-1
EMC	Cabinet: EN61439-1, EN61439-2 Inverter & bypass modules: EN61000-6-1 / -2 / -3 / -4 Generic

Bypass AC Input	
Nominal input voltage	200-240 VAC, 50-60Hz, 1-phase
Nominal input current	27 Amps
Input protection	MCB C32A
Input Connector X2, cabinet	Screw terminal 10mm ² , L-N-PE

Inverter's DC input	24 V		48V - 60 V		110V – 125 V		220 V	
	No Fans	Fan cooled	No Fans	Fan cooled	No Fans	Fan cooled	No Fans	Fan cooled
Nominal voltage	24 VDC		48 VDC / 60 VDC		110 VDC / 125 VDC		220 VDC	
Voltage range	20-32 VDC		40-72 VDC		88-150 VDC		178-275 VDC	
Nominal current at nom. voltage -10% (1.8vpc)	5 x 33 A	5 x 45 A	5 x 19A	5 x 32A	5 x 8A	5 x 14A	5 x 4A	5 x 7A
Max current, 5 sec overload	5 x 75A		5 x 50A		5 x 22A		5 x 11A	
Recommended external fuse	250A		200A		80A		40A	
Input Protection per module	MCB C63A		MCB C40A		MCB C25A		MCB C16A	
Input connector X1, cabinet	Screw terminal 95mm ² , +/-		Screw terminal 95mm ² , +/-		Screw terminal 50mm ² , +/-		Screw terminal 50mm ² , +/-	
Input switch S1	Main Switch 250A		Main Switch 200A		Main Switch 125A		Main Switch 63A	

AC output	24 V		48V - 60 V		110V – 125 V		220 V	
	No Fans	Fan cooled	No Fans	Fan cooled	No Fans	Fan cooled	No Fans	Fan cooled
Output voltage and frequency	On-line mode: Nominal 230 VAC/50Hz sine wave, user programmable 200–240V / 50–60 Hz Off-line mode: Mains voltage and frequency, transfer time to backup supply 4msec (programmable)							
Nominal max power	5kVA / 3kW	6kVA / 4kW	5kVA/3.5kW	6kVA / 6kW	5kVA/3.5kW	6kVA / 6kW	5kVA/3.5kW	6kVA / 6kW
Max continuous current	5 x 4.4 A	5 x 5.2 A	5 x 4.4 A	5 x 5.2 A	5 x 4.4 A	5 x 5.2 A	5 x 4.4 A	5 x 5.2 A
Overload capacity, 5 sec	5 x 1200 W		5 x 1700 W		5 x 1700 W		5 x 1700 W	
Overload capacity, 60 sec	110% for all models, number of restart attempts and delays are user programmable							
Max short circuit current	5 x 13 A / 1-4 sec							
Load Distribution	Bulk terminal X3 / 10 mm ² , configurable load MCB 2-pole + aux, 1-5pcs							

Connections	
Bypass AC Input, cabinet	Screw terminal X2, 10mm ² , L-N-PE, MCB C32A 1-pole
DC Input inverters, cabinet	Screw terminal X1, 50-95mm ² , fuse protection per inverter module, see above
AC Load bulk output	Screw terminal XL1, 10mm ² , L-N-PE
AC load distribution	Configurable 2-pole load MCBs + aux contacts, LF11-FL15, 1-5pcs
Relay alarms, 3pcs	Screw terminals X3-X5, 4mm ² , summary alarm, backup supply, load fuse fault
Integration to OPUS systems	VIDI Controller, VIDI-SAM aux controller and User Interface needed for integration

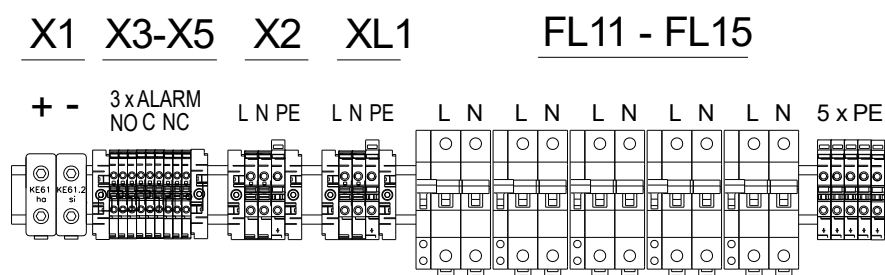

V i t e c POWER GmbH

Bahnstraße 65-67/2/2, A-2230 Gänserndorf, Austria, Tel.: +43 (0)2282 3144, Email: office@vitecpower.com

www.vitecpower.com

Block Diagram, Configurable Wall Cabinet options

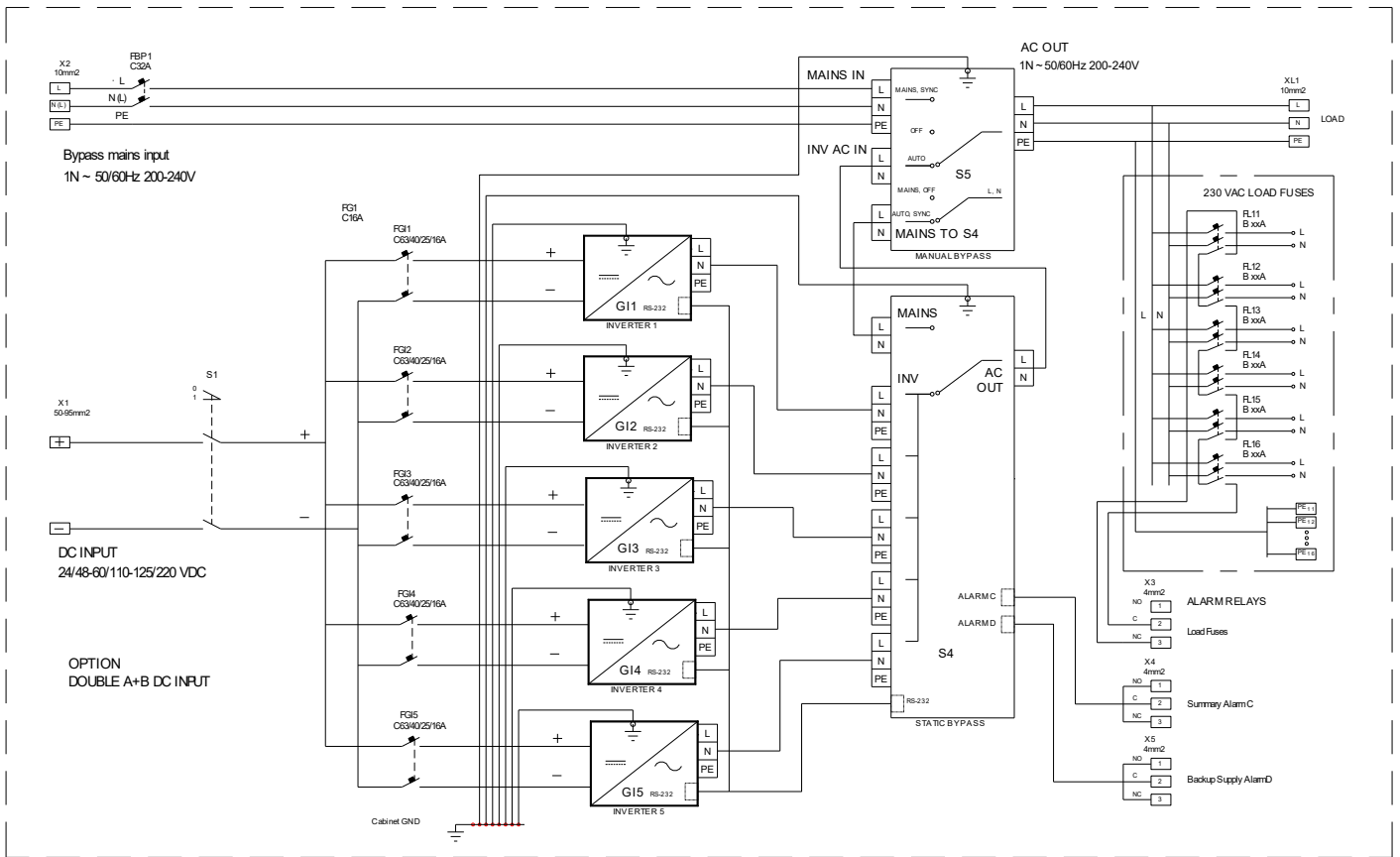

Mechanical Dimensions

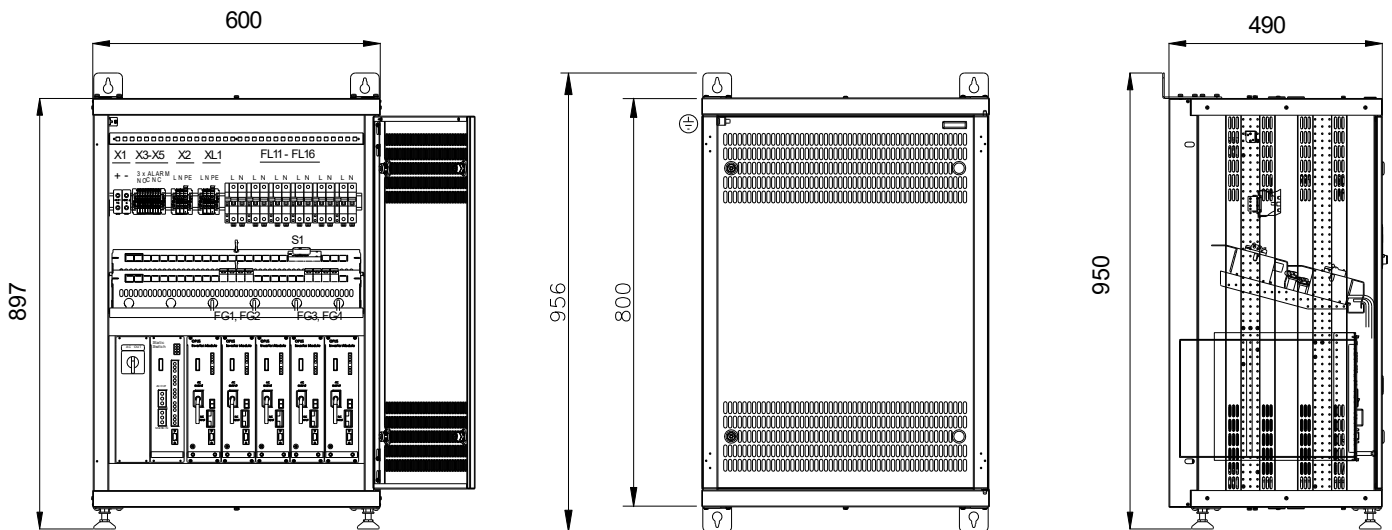

Order Information

Systems, Description	Order number	Voltage / Power
OPUS INV 24-6.0 OC0864 F	922X015892	24VDC / 230VAC 1kVA – 6kVA
OPUS INV 48/60-6.0 OC0864 F	922X015893	48V-60DC / 230VAC 1kVA – 6kVA
OPUS INV 110/125-6.0 OC0864 F	922X015894	110-125VDC / 230VAC 1kVA – 6kVA
OPUS INV 220-6.0 OC0864 F	922X015895	220VDC / 230VAC 1kVA – 6kVA

INV module 1kVA natural cooling	INV module 1.2kVA fan cooling
EIM62132VF	EIM62232VF
EIM62134VF	EIM62234VF
EIM62135VF	EIM62235VF
EIM62136VF	EIM62236VF