

OPUS HE DC Power Systems Wall Mounted Charger

OPUS HE WMC 24-1500 F
 OPUS HE WMC 48-2000 F
 OPUS HE WMC 60-2000 F
 OPUS HE WMC 110-2000 F
 OPUS HE WMC 125-2000 F
 OPUS HE WMC 220-2000 F



Product Description

OPUS HE WMC Wall Mounted Chargers are robust and free convection cooled backup power solutions. Together with external battery bank it provides reliable and cost-effective uninterrupted DC supply for critical infrastructure applications such as transmission and distribution substations, process industries, railway signalling and telecommunications.

OPUS HE DC power systems consist of MHE rectifier, VID12 controller, Connections for mains and battery and load distribution MCB. System is configurable to meet requirements of the application. On top of 12 configurable relay alarms, system can be remotely monitored via modern communication protocols such as Ethernet TCP/IP, Modbus TCP/IP, SCADA IEC61850, SNMP and RS-232.

WMC Wall Mounted Charger product line consists of MHE rectifier, VID12 controller, MCB protections for mains, load and battery packaged in wall mounted IP21 enclosure. Charger delivers 2kW output power at 48V, 60V, 110V, 125V and 220 V battery systems and 1.5kW at 24 V systems.

Features

- Efficiency up to 97%
- Convection cooling – no fans
- Outputs 24, 48, 60, 110, 125, 220 VDC
- Easy installation
- Battery MCB for one string
- Configurable load distribution 1-3 x MCB 2p+aux
- Configurable A+B double charger set-up
- VID12 controller, local and remote interfaces
4 x relays, Ethernet, Modbus, SNMP, RS-232, SCADA IEC61850
- Battery LVD, battery midpoint and block voltage monitoring, battery temp.sensor, battery state of health monitoring
- Safety:
EN61439-1, EN61439-2
Low voltage switchgear and controlgear assemblies
- EMC:
EN 61000-6-1 / -2 / -3 / -4 / -5
ETSI EN 300386 (48/60V)

Technical Specifications

General construction	
Cooling	Natural convection
Protection	IP21
Controller user interface	Display and local control in front door & web interface
Cabling	Bottom entry
Colour	RAL 7024
Dimensions & weight	H 520 mm x W 400 mm x D 200 mm 15kg

Environment and standards	
Temp. range	-25 ... +60°C, see derating, Start-up at -40°C
Humidity max	95% relative humidity, non-condensing
Altitude	Max 3km, full power up to 2km above sea level Derating 2% per 100 m between 2-3km
Safety	EN61439-1, EN61439-2
EMC	EN61000-6-1 / -2 / -3 / -4 Generic EN61000-6-5 Utility, surge level 2 ETSI EN 300386 (48/60V)

AC Input	
AC connection	L + N + PE (option 2 x L + PE)
Nominal input	200-250 VAC 50/60Hz
Input range	Max range: 85 – 300 VAC Rated full power range: 180 – 275 VAC See derating curves below, 1200W per rectifier at 120VAC Temporary high voltage range 275 - 300VAC, continuous supply not recommended
Input frequency	Rated 45 - 66 Hz, reduced power at 35 - 45 Hz. Shut down at 35 Hz
Main Switch	16A, 2-pole
Rectifier input protection	MCB C16A 1-pole
	24V 48V 60V 110V 125V 220V
Nominal current	8A @ 220V 11A @ 220VAC
Maximum current	12,5A @ 85-130V 12,5A @ 85-180VAC
Recommended mains fuse	25 A

DC Output	24V	48V	60V	110V	125V	220V
Grounding	2-pole, floating					
Nominal voltage	24 VDC	48 VDC	60 VDC	108 VDC	120 VDC	216 VDC
Voltage factory setting, 2.27vpcc	27.24 VDC	54.48 VDC	68.10 VDC	122.58 VDC	136.20 VDC	245.16 VDC
Voltage range	21-33 VDC	42-59 VDC	51-72 VDC	90-150 VDC	100-160 VDC	178-280 VDC
Static voltage regulation	± 1 % @ load terminals (load, line, temp)					
Max current	62.5A @ 24V	41.7A @ 48V	33.3A @ 60V	18.5A @ 108V	16.7A @ 120V	9.3A @ 216V
Max Power	1.5kW	2kW	2kW	2kW	2kW	2kW
Rectifier module output protection, 1-pole	MCB C63A	MCB C50A	MCB C40A	MCB C20A	MCB C20A	MCB C10A
Battery fuse, 2-pole + aux	MCB D63A	MCB D63A	MCB D63A	MCB D63A	MCB D63A	MCB D63A
Load fuses, configurable	Default: 1-3 x MCB 2-p + aux Alternatively: 1-4 x MCB 2-p no aux, 1-5 x MCB 1-p+aux, 1-8 x MCB 1-p no aux					

Connection terminals	
Mains terminal	Terminal blocks 2.5 mm ² , L + N (L) + PE
Battery MCB	Tunnel type terminals, 1...50 mm ² rigid cable / 1.5...35 mm ² flexible cable
Load	Load MCB Screw terminals
A+B parallel supply MCN	Tunnel type terminals, 1...50 mm ² rigid cable / 1.5...35 mm ² flexible cable
Alarms & Inputs	Configurable relay alarms 4 pcs, Spring terminals 0.75mm ² ... 1.5mm ² cable Configurable external alarm/temp. inputs 2 pcs, Spring terminals 0.75mm ² ... 1.5mm ² cable

Derating curves

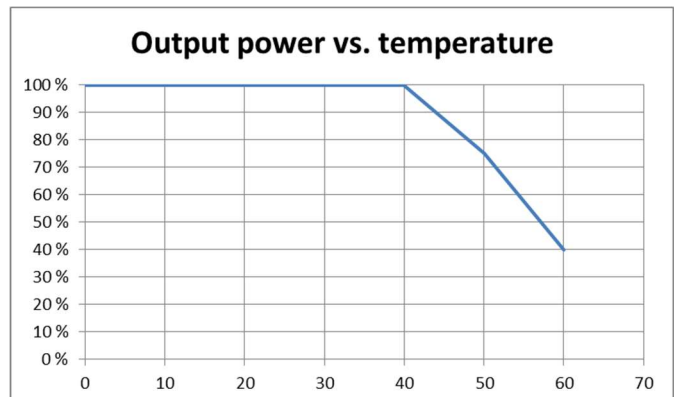
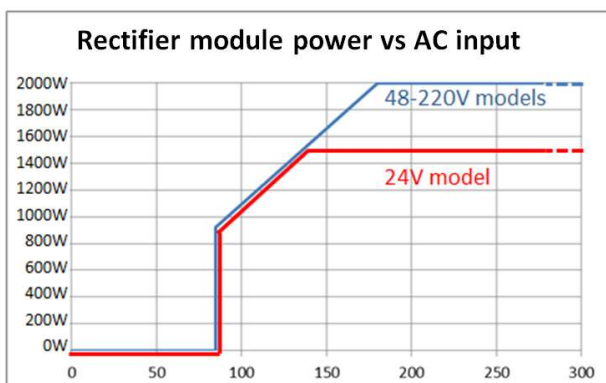

Layout drawing

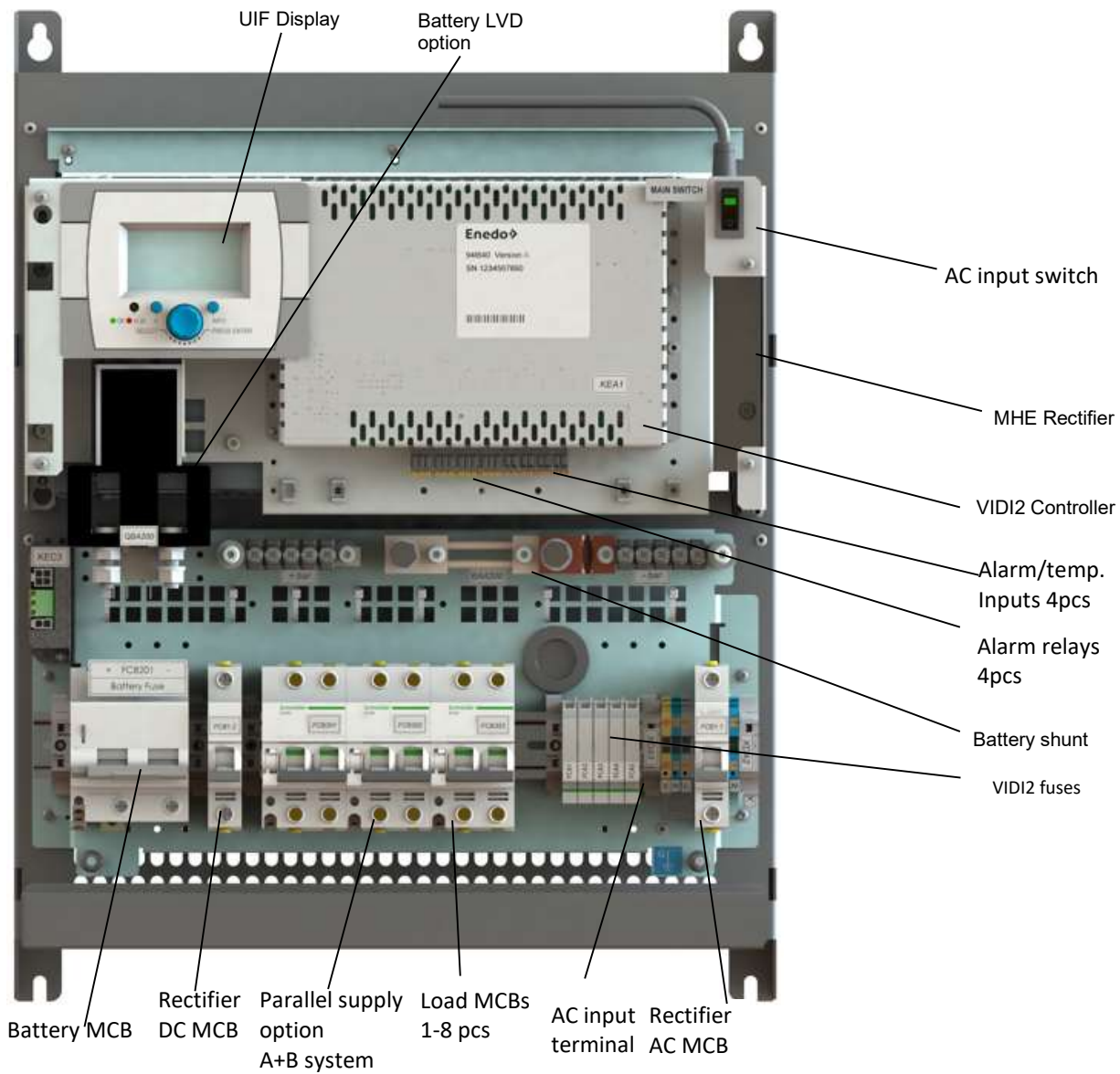

Block Diagram

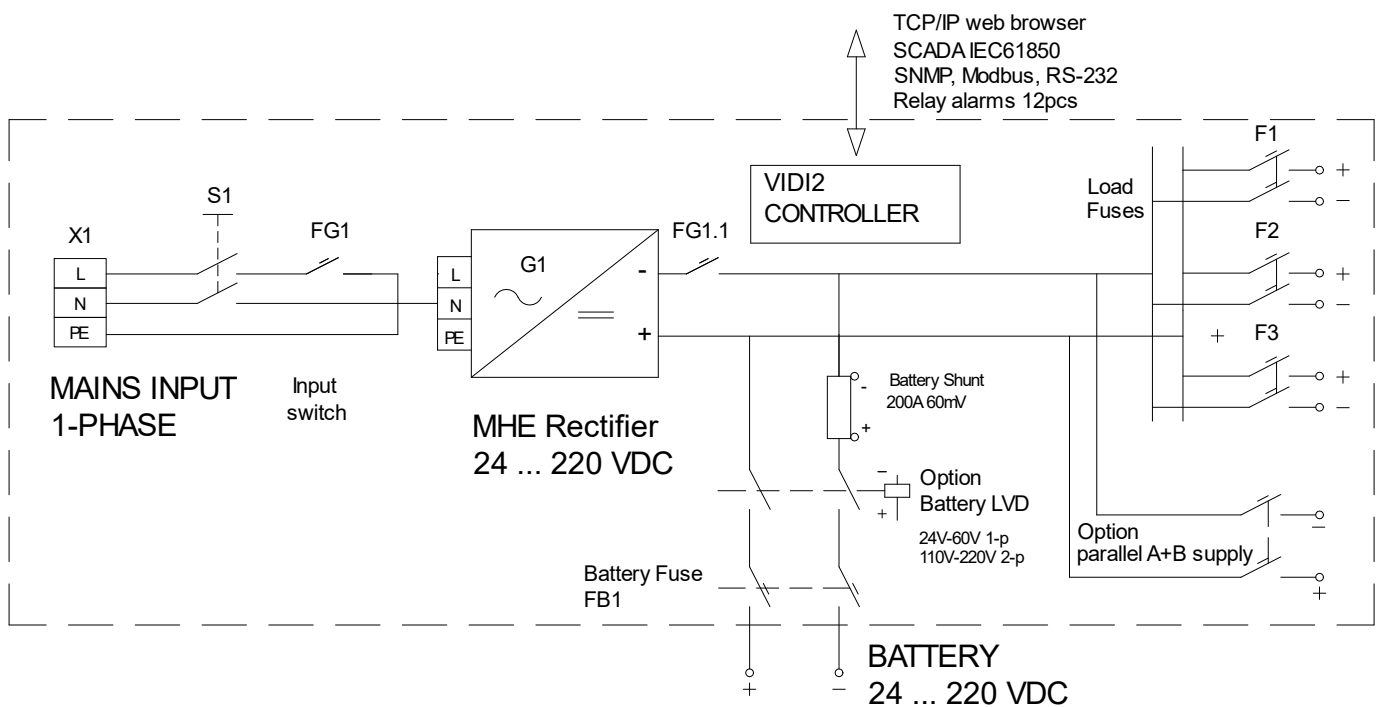

Vitec POWER GmbH

Bahnstraße 65-67/2/2, A-2230 Gänserndorf, Austria, Tel.: +43 (0)2282 3144, Email: office@vitecpower.com

www.vitecpower.com

Application Note: A + B double systems & external distribution panels

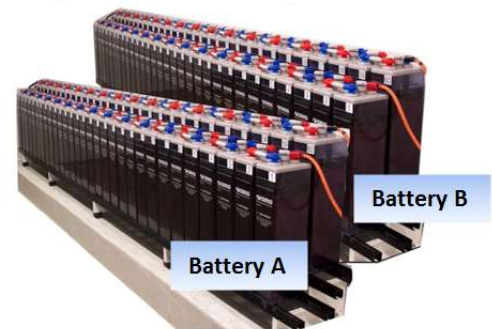
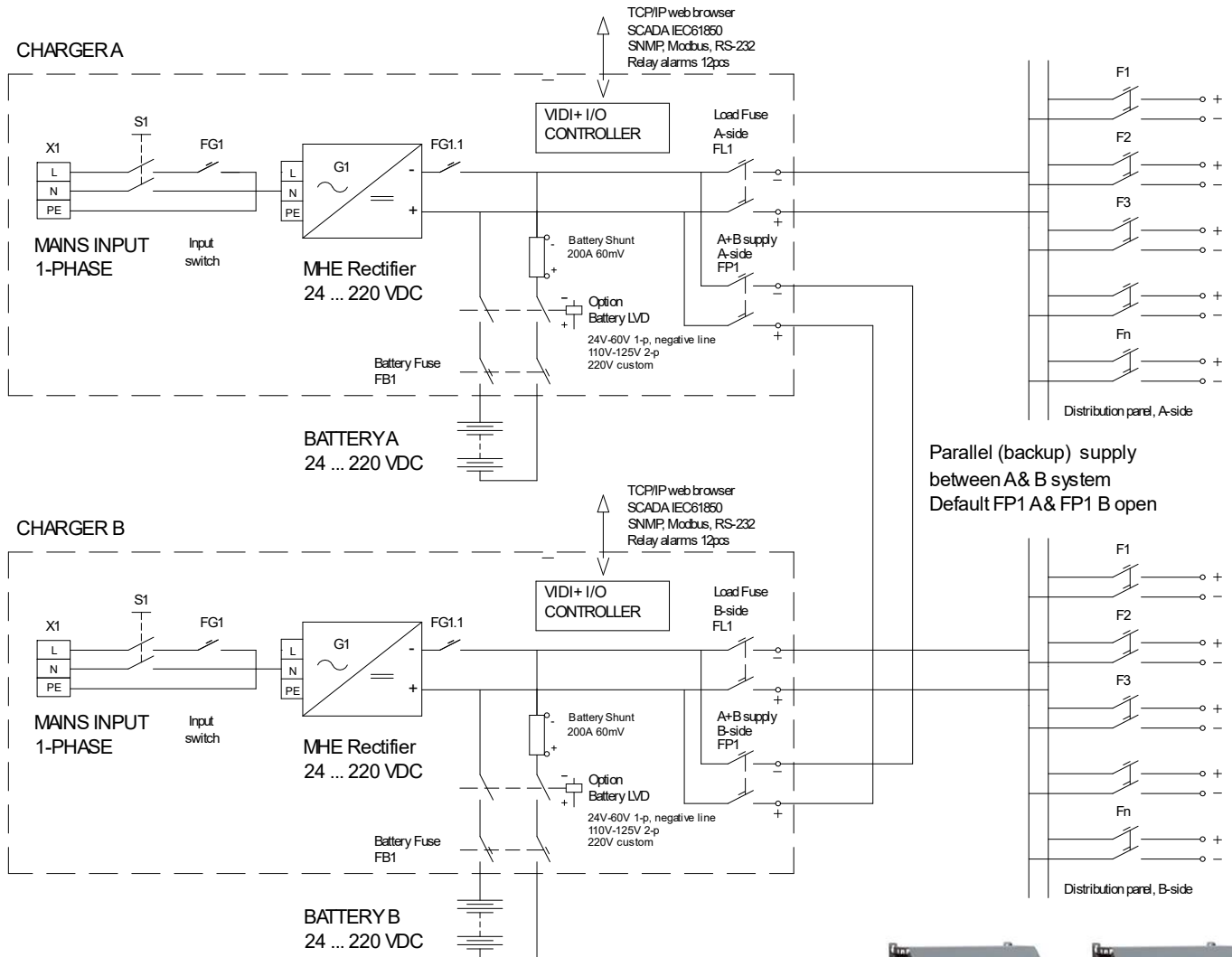

Order Information

Systems, Description	Order number	Voltage / Current
OPUS HE WMC 24-1500 F	922XW11257	24VDC / 62.5A
OPUS HE WMC 48-2000 F	922XW11286	48VDC / 41.7A
OPUS HE WMC 60-2000 F	922XW11287	60VDC / 33.3A
OPUS HE WMC 110-2000 F	922XW11269	110V / 18.5A
OPUS HE WMC 125-2000 F	922XW11270	125V / 16.7A
OPUS HE WMC 220-2000 F	922XW11276	220V / 9.3A

Configurable features	Order number
Temperature Sensor	94M268
BLVD 24V 100A 1-P OPUS WMC/WRS	8320X0014246
BLVD 48/60V 100A 1-P OPUS WMC/WRS	8320X0014337
BLVD 110/125V 100A 2-P OPUS WMC/WRS	8320X0015456
Parallel supply, A+B system, MCB 63A 2-p+aux	832X015908

Vitec POWER GmbH

Bahnstraße 65-67/2/2, A-2230 Gänserndorf, Austria, Tel.: +43 (0)2282 3144, Email: office@vitecpower.com

www.vitecpower.com