

OPUS HE 24-4.5 R5U F
OPUS HE 48/60-6.0 R5U F
OPUS HE 110/125-6.0 R5U F
OPUS HE 220-6.0 R5U F



Default UIF position
no front door



Optional front door
Alternative UIF position in front door

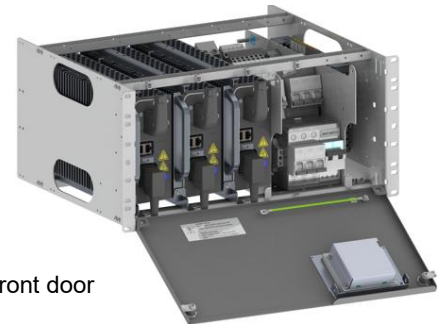

Product Description

OPUS HE power systems are robust, free convection cooled, N+1 redundant backup power solutions for critical infrastructure applications such as transmission and distribution substations, process industries, railway signalling and substations and telecommunications.

OPUS HE DC power systems consist of MHE rectifiers, VID12 controllers, Connections for mains and battery and load distribution. System is configurable to match with requirements of the application. Additionally 5U rack can be cost optimized and delivered as building block assembly KIT for local system building partner.

19" 5U Rack delivers maximum 6 kW output power at 48, 60, 110, 125 and 220 VDC and 4.5 kW at 24 VDC output. 19" 5U Racks include slots for maximum 3 rectifier modules, battery breakers and shunt for one string and bulk DC load output. Wall mounting, IP21 cover kit, temperature sensor, battery block voltage monitoring and BLVD are options. Master-slave set-up can be used to increase power higher than 6kW.

Features

- Efficiency up to 97%
- Convection cooling – no fans
- Outputs 24, 48, 60, 110, 125, 220 VDC
- 6.0 kW output power, 24VDC 4.5kW
- Building block rack for cabinet integration, Master-Slave 2 x 5U rack – power up to 16kW
- VID12 controller, local and remote interfaces 12 x relays, Ethernet, Modbus, IEC61850, SNMP, RS-232
- Flexible design with full front cabling
- Battery midpoint monitoring, battery state of health monitoring
- Options: Wall mounting and IP21 kit, BLVD contactor, battery block voltage monitoring
- Safety:
 - Rack: EN61439-1, EN61439-2
 - Rectifiers: EN 62368-1, EN 50124-1 rail
- EMC:
 - EN 61000-6-1 / -2 / -3 / -4 / -5
 - EN 50121-4/-5 rail, ETSI EN 300386 (48/60V)

Technical Specifications

General construction		Environment and standards	
Cooling	Natural convection	Temp. range	-25 ... +60°C, see derating, Start-up at -40°C
Protection	IP 20, Option IP21	Humidity max	95% relative humidity, non-condensing
Controller user interface	Display in front door or inside the rack, LAN connection, VID12	Altitude	Max 3km, full power up to 2km above sea level Derating 2% per 100 m between 2-3km
Connections	Behind front panel	Safety	Rack: EN61439-1, EN61439-2 Rectifiers: EN 62368-1, EN 50124-1 rail
Colour	Frame RAL 7024	EMC	EN61000-6-1 / -2 / -3 / -4 Generic EN61000-6-5 Utility, surge level 2 EN 50121-4/-5 Rail, signaling and substation ETSI EN 300 386 (48/60V) telecom
Dimensions & weight	Height 5U (222 mm) Width 19" (482 mm) Depth 380 mm Weight 15 kg w/o rectifiers		

AC Input	OPUS HE 24-4.5 R5U F	OPUS HE 48-6.0 R5U F	OPUS HE 60-6.0 R5U F	OPUS HE 110-6.0 R5U F	OPUS HE 125-6.0 R5U F	OPUS HE 220-6.0 R5U F
AC connection	TN-S system, 3W + N + PE, (3-phases, neutral and protective earth wires)					
Nominal input	220-240 VAC / 3 x 380-415 VAC (TN-S system) <i>Options: 1-phase supply 100-250VAC, 3-phase Delta/IT supply 3 x 173-250VAC</i>					
Input range	Max range: 85 – 300 VAC / 3 x 147–528 VAC Rated full power range: 180 – 275 VAC / 3 x 312–476 VAC (TN-S system) See derating curves below, 1200W per rectifier at 120VAC / 3 x 208VAC Temporary high voltage range 275 - 300VAC / 3 x 476 - 528VAC, continuous supply not recommended					
Input frequency	Rated 45 - 66 Hz, reduced power at 35 - 45 Hz. Shut down at 35 Hz					
Nominal current	8A @ 220/380V			11A @ 220/380VAC		
Maximum phase current	12,5A @ 85-130V			12,5A @ 85-180VAC		
Recommended mains fuse	3 x 25 A (TN-S)					
Main Switch	20A, 4-pole (L1-L2-L3-N)					
Rectifier input protection	MCB C16A / rectifier module					

DC Output	OPUS HE 24-4.5 R5U F	OPUS HE 48-6.0 R5U F	OPUS HE 60-6.0 R5U F	OPUS HE 110-6.0 R5U F	OPUS HE 125-6.0 R5U F	OPUS HE 220-6.0 R5U F
Grounding	2-pole, floating					
Nominal voltage	24 VDC	48 VDC	60 VDC	108 VDC	120 VDC	216 VDC
Voltage factory setting	27.24 VDC	54.48 VDC	68.10 VDC	122.58 VDC	136.20 VDC	245.16 VDC
Voltage range	21-33 VDC	42-59 VDC	51-72 VDC	90-150 VDC	100-160 VDC	178-280 VDC
Quantity of rectifiers	Max 3 pcs					
Max current	187.5A @ 24V	125A @ 48V	100A @ 60V	55.5A @ 108V	50A @ 120V	27.8A @ 216V
Max Power	Max 4.5kW *)	Max 6kW	Max 6kW	Max 6kW	Max 6kW	Max 6kW
Static voltage regulation	± 1.5 % @ rack terminals (load, line, temp)			± 1 % @ rack terminals (load, line, temp)		
Rectifier output protection	MCB C63A	MCB C50A	MCB C50A	MCB C20A	MCB C20A	MCB C10A

*) Battery MCB D125A, max battery current 125A

Battery connection	OPUS HE 24-4.5 R5U F	OPUS HE 48-6.0 R5U F	OPUS HE 60-6.0 R5U F	OPUS HE 110-6.0 R5U F	OPUS HE 125-6.0 R5U F	OPUS HE 220-6.0 R5U F
Protective device	MCB D125A 2-pole + aux	MCB D125A 2-pole + aux	MCB D125A 2-pole + aux	MCB D63A 2-pole + aux	MCB D63A 2-pole + aux	MCB D63A 2-pole + aux

Connection terminals	
Mains terminal	Q1 Main switch, 10 mm ² screw terminals, L1-L2-L3-N-PE
DC output	Bulk output X2, screw terminals 35 mm ²
Battery	MCB screw terminals, 1.5...35 mm ² flexible cable, 1...50 mm ² rigid cable
Alarms, Inputs	Configurable relay alarms 4 pcs (option up to 12), Spring terminals 0.75mm ² ... 1.5mm ² cable Configurable alarm/temp. inputs 4 pcs (option up to 12), Spring terminals 0.75mm ² ... 1.5mm ² cable

Derating curves

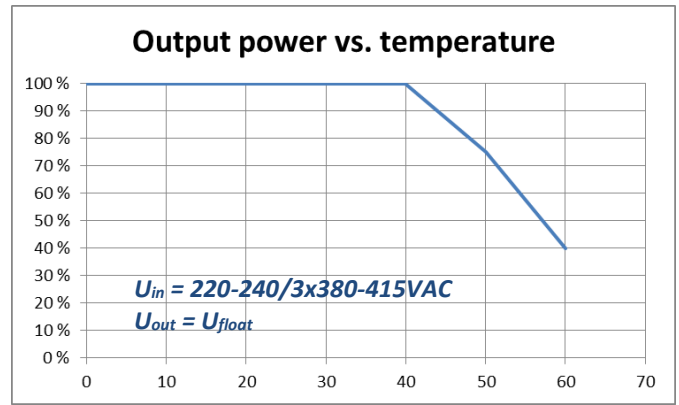
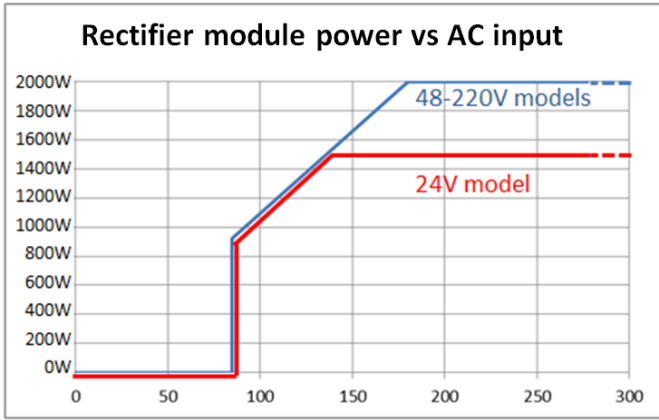

Block Diagram, 2-pole floating systems

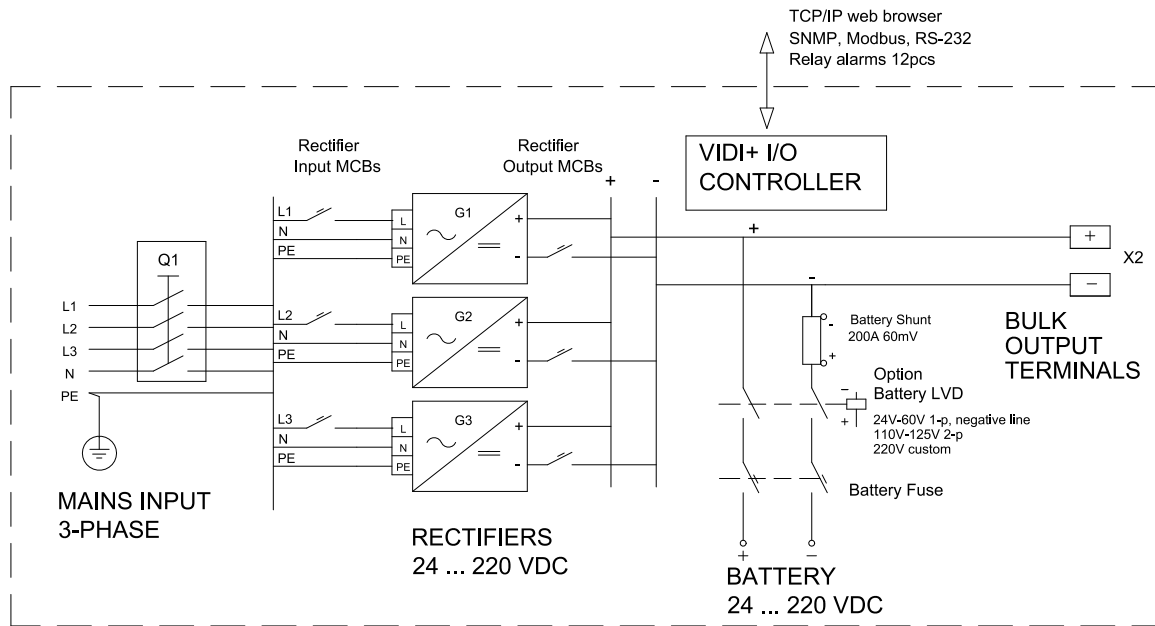

Block Diagram, Master-Slave connection up to 16kW

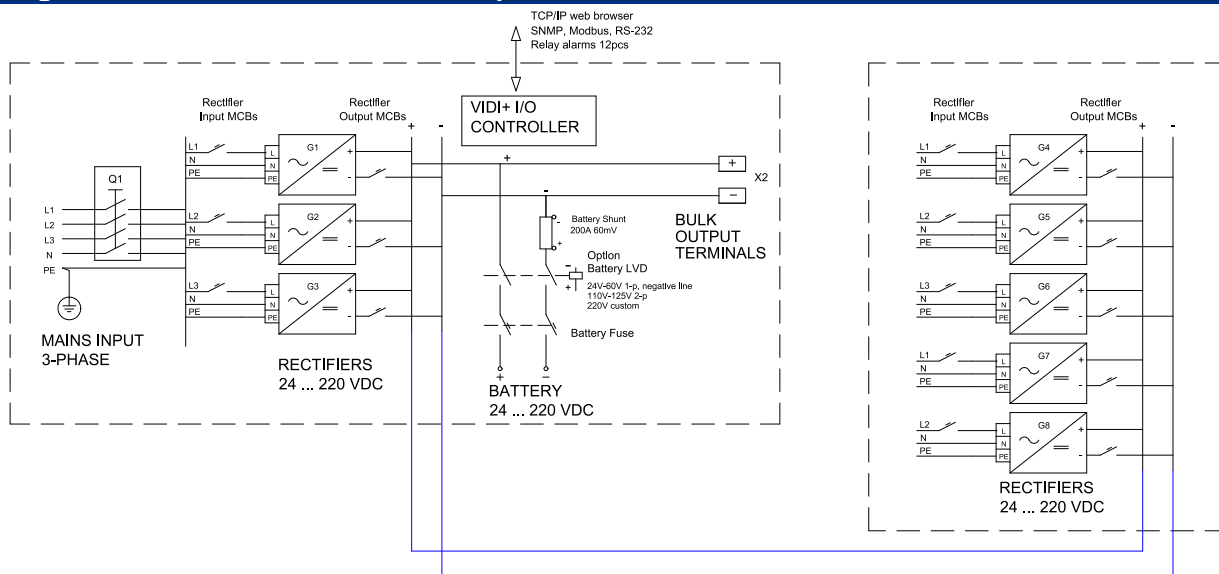

Layout drawings, basic rack system

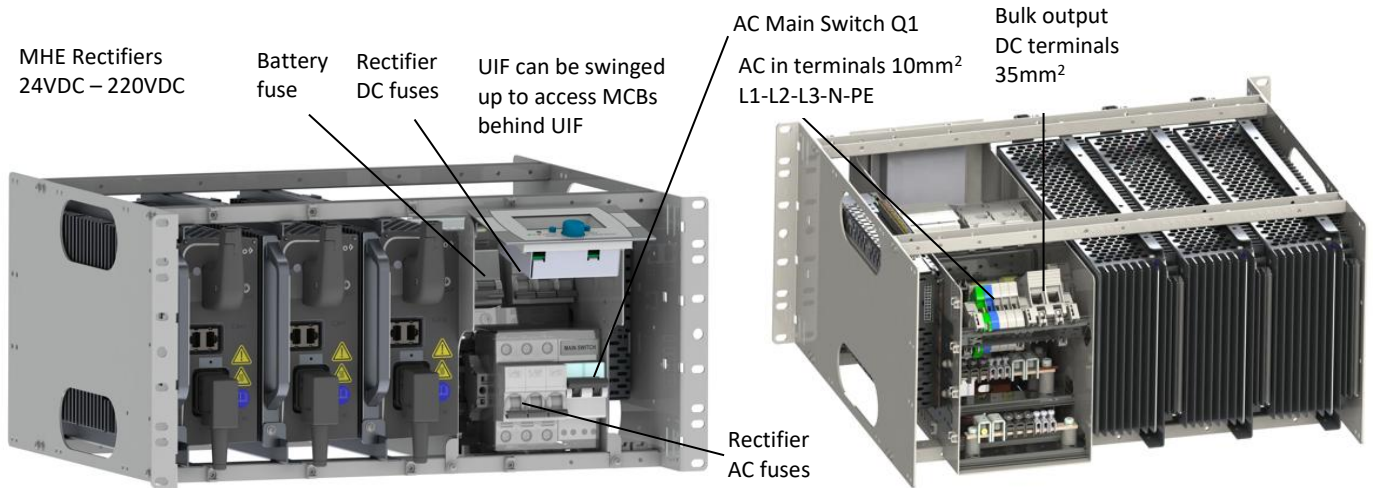

OPUS HE 5U Rack Modules and 19" Distribution panels

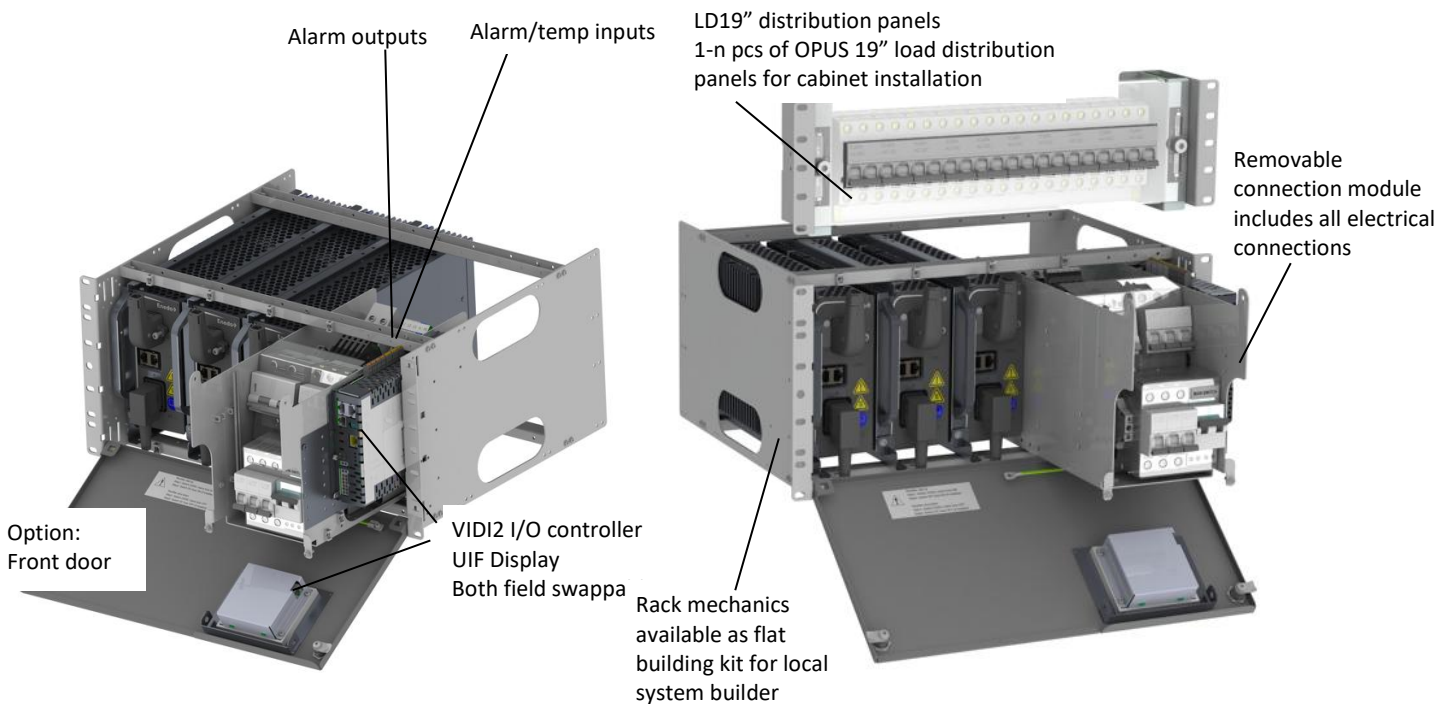

Dimensions

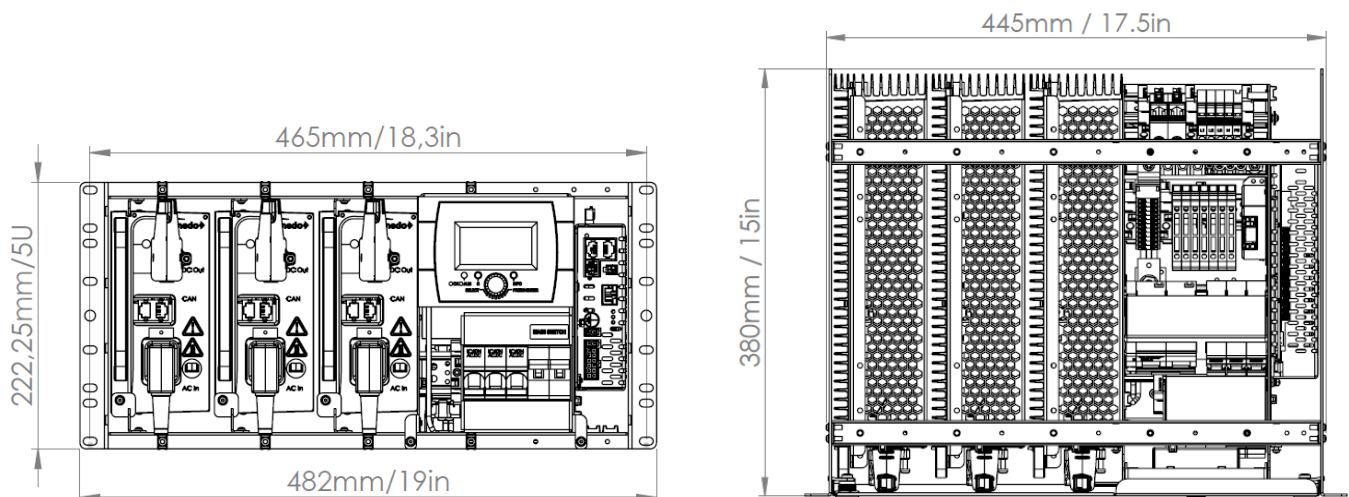

Vitec POWER GmbH

Bahnstraße 65-67/2/2, A-2230 Gänserndorf, Austria, Tel.: +43 (0)2282 3144, Email: office@vitecpower.com

www.vitecpower.com

Order Information, complete 5U racks

Systems, Description	Order number	Voltage / Current	Rectifiers	Order number
OPUS HE 24-4.5 R5U F	922XW16076	24VDC / 62.5A – 187.5A	MHE24-1500	92I280
OPUS HE 48/60-6.0 R5U F	922XW16074	48VDC / 41.7A – 125A	MHE48-2000	92I160
OPUS HE 48/60-6.0 R5U F	922XW16074	60VDC / 33.3A – 100A	MHE60-2000	92I290
OPUS HE 110/125-6.0 R5U F	922XW16077	110V / 18.5A – 55.5A	MHE110-2000	92I250
OPUS HE 110/125-6.0 R5U F	922XW16077	125V / 16.7A – 50A	MHE125-2000	92I260
OPUS HE 220-6.0 R5U F	922XW16098	220V / 9.3A – 27.8A	MHE220-2000	92I270
OPUS HE 19" 5U SLAVE RACK	832X016097	24-220V / up to 10kW	MHE	Any voltage
OPUS HE 23" 5U SLAVE RACK	D02787	24-220V / up to 12kW		

Controllers, Description	Order number	Options, Description	Order number
VIDI2 System controller	94I640	VIDI2-EFD module KIT	D02311

Options, Description	Order number	Options, Description	Order number
Temperature Sensor	94M268	BLVD 24V 200A 1-P R 5U P	D02236
Battery Midpoint cable 5m	D01992	BLVD 48/60V 200A 1-P R 5U P	D02212
Wall mounting and IP21 kit 5U	D02764	BLVD 110/125V 100A 2-P R 5U F	D02235

Load Distribution panels	Order number	Load Distribution panels	Order number
10 x MCB 2-p, FMU, 24V-60V, 19" 3U	832X016086	8 x MCB 2-p+aux, 24V-220V, 19" 3U	832X016110
10 x MCB 2-p, FMU, 110-220V, 19" 3U	832X016087	14 x MCB 1-p+aux, 24-220V, 19" 3U	832X016111

Order Information, 5U building block sets

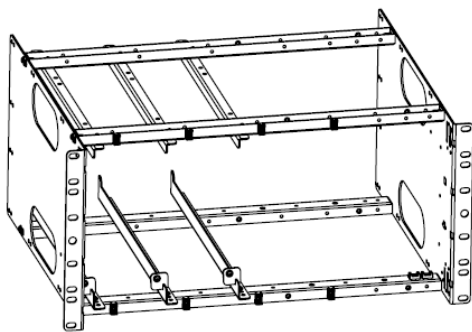

D02062 B
MECHANICAL RACK FOR 3 RECTIFIERS

Unassembled, delivered as flat packing

Connection modules

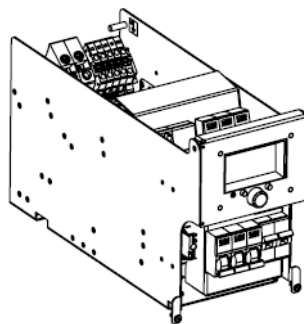

24VDC = 832X016101
 48VDC = 832X016102
 60VDC = 832X016103
 110VDC = 832X016104
 125VDC = 832X016105
 220VDC = 832X016106

All connections are done in connection module. Module if fully tested with VIDI & UIF and ready for local panel builder.

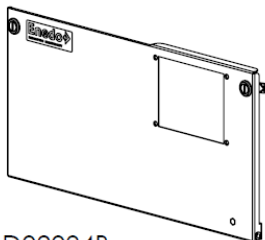

D02094B
FRONT PANEL KIT

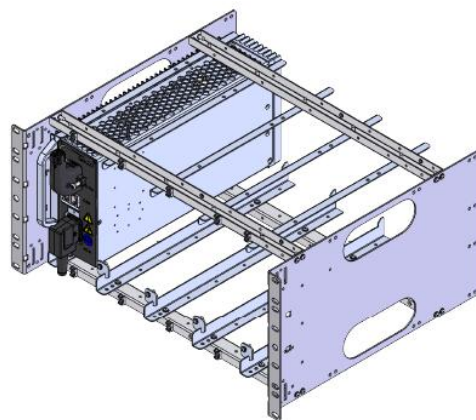

832X016097
 OPUS HE R5U 19" RACK for 5 x MHE, no cables
 Width 19" x Height 5U x Depth 380 mm
 Specify per order assembled or flat packed

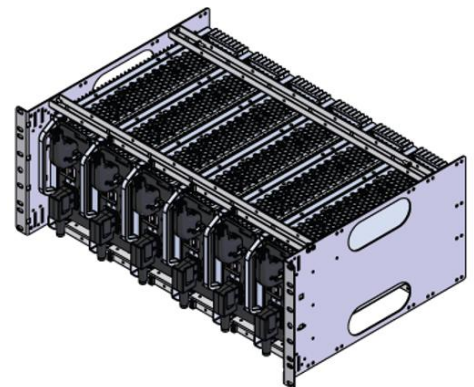

D02787
 OPUS HE R5U 23" RACK for 6 x MHE, no cables
 Width 23" x Height 5U x Depth 380 mm
 Specify per order assembled or flat packed