



## AC Distribution, Static Switch and Manual Bypass for DAC60000 DUAL Inverters



AC-distribution  
3 pcs of MCBs

Manual bypass  
switch

BPU69000 Dual  
External static switch  
Plug-in unit

19" 1.5U power frame  
Connections in rear panel  
and mounting to 19"

### Modular Construction

DAC60000 Dual inverter system consists of separate modules, which can be included in the system based on customer's needs. The system may include static switch, manual bypass and AC-distribution or only some of these features.



### Complete Inverter System

MBP68300 fits ideally to be used with DAC60000 Dual 19" 1.5U inverters. Up to 6pcs of 1500VA inverters max 7.5kVA n+1 can be installed in parallel including external static switch, manual bypass and AC-distribution. MBP68300 and inverters are installed on top of each other in 19" cabinet.

Voltage 100...240VAC • Power rating 7.5kVA • 4 position manual bypass rotating switch

- 10mm<sup>2</sup> screw terminals for mains in and load, see details next page

### System level connection circuit:

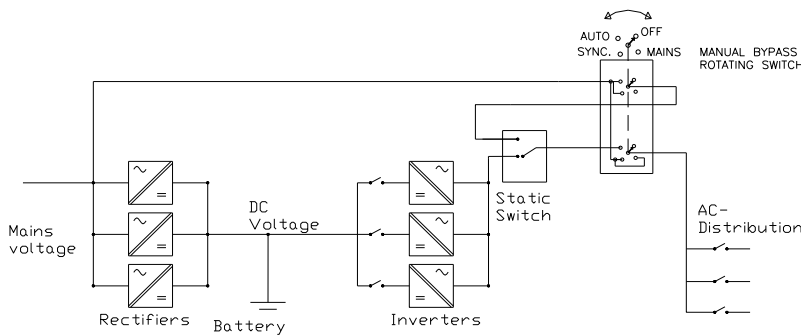

#### Manual bypass switch positions:

- OFF  
No supply
- MAINS  
Mains supply, No mains input for static switch
- SYNC  
Mains supply, Mains input connected to static switch



**Note**  
**Recommendation:**  
Set the static switch to off-line mode before turning between SYNC and AUTO

- AUTO  
Inverter System supply on-line or off-line

MANUAL BYPASS AND AC-DISTRIBUTION TYPE NUMBERS	
Type	Description
MBP68300	Manual bypass 7.5kVA 19" 1.5U x 480mm
MBP68360	Manual bypass 7.5kVA and AC-distribution unit for 3 pcs of output MCBs, 19" 1.5U x 480mm Select MCBs from table below, any combination is possible

STATIC SWITCH UNITS AND MECHANICAL PARTS	
Type	Description
BPU69230FR	External static switch, 7500VA 230VAC, 220mm x 64mm x 409mm module

MCB ALTERNATIVES FOR MBP68360 AC DISTRIBUTION			
Type / Description	Type / Description	Type / Description	Type / Description
54100100 1A C-curve	54100600 6A C-curve	54101600 16A C-curve	54102500 25A C-curve
54100200 2A C-curve	54101001 10A B-curve	54102001 20A B-curve	54103201 32A B-curve
54100400 4A C-curve	54101000 10A C-curve	54102000 20A C-curve	54103200 32A C-curve
54100601 6A B-curve	54101601 16A B-curve	54102501 25A B-curve	54104001 40A B-curve

## Specification

### ELECTRICAL

Voltage range	Static Switch	80-270VAC
Current	Static Switch nominal current	33A
	Manual bypass wiring	up to 40A
Frequency		40...70Hz
Safety		According to EN60950-1, Class I
Mains input connector	L, N, PE	3-pole 10mm <sup>2</sup> screw terminal
Inverter/static switch input	Inverter system output to static switch	With AC bus bars, M5 ring terminals
	Static switch output to Manual bypass	Internally wired
AC outputs connector	1L-3L, 1N-3N, 1PE-3PE	3x3-pole 10mm <sup>2</sup> screw terminal
	All connectors are located on rear panel	
Grounding	10mm <sup>2</sup> screw terminal and M5 bolt	1+3 pcs on rear panel
Mains supply fuse	max 50A	External
Internal wiring	6 mm <sup>2</sup>	Halogen-free, 105°C

### CONTROLS

Manual bypass switch (1s)	Rotating switch K&N CA40 , 4 positions	max current 40A, short circuit max 950A
Distribution	1-3pcs of MCB safety switches	On front panel, 1-40A B or C curve

### MECHANICAL

Dimensions	Height	1,5U (66mm)
	Width	19" (483mm)
	Depth	480mm (+ handles 20mm)
Weight		6,6 kg
Enclosure	hot galvanized steel	IP20
Front plate painted		RAL7035
Finger protection	Polycarbonate plate	Covers rear panel's screw terminals

### ENVIRONMENTAL

Temperature range	Operating	-25°C...+50 °C
	Storage	-40°C...+70 °C

## Operating and connecting the Manual bypass

### 1. General

MBP68300 series is manual bypass (=MBP) with or without AC-distribution unit for Enedo Dual inverter systems. Manual bypass is included in MBP68300/MBP68360 19" 1.5U power frame. To the righthand side of MBP unit will be installed static switch plug-in module. Manual bypass is internally wired to static switches plug-in connectors in power frame.

By manual bypass AC loads can be supplied directly from mains to loads bypassing the inverter system. The inverter system can be also totally switched off by manual bypass switch. In normal operation mode (AUTO) inverter system supply (static switch AC output, online or offline) is distributed to loads via manual bypass. Also 1...3pcs of AC-distribution fuses can be included to MBP unit.

Two different variants are available:

MBP68300 Dual manual bypass switch without AC-distribution

MBP68360 Dual manual bypass and AC-distribution unit

## 2. Mounting the MBP power frame to 19"

The frame unit is mounted to the 19" rack cabin by 4pcs of M6 (M5) screws from the front panel.

There is no need for additional space between the power frames. But the air flow from front to back must be free. The same spacing that the inverters need is enough also for the manual bypass power frame.

## 3. Mounting the Static switch to MBP power frame

BPU69000 DUAL static switch module is mountable to MBP68300/MBP68360 power frame. Plug the module in to the free slot. Secure the connection with the lever (screw is optional). Static switch module needs to be mounted inside a cabinet to fulfill EN60950 safety regulations.

There is no need for additional space between the power frames. But the air flow from front to back must be free. The same spacing that the inverters need is enough also for the MBP power frame.

## 4. Connecting the cables

### See figure 1:

MBP68360 + MSR8170 rear panel wiring with one inverter module.

See also chapter 8 EMC considerations.

For DC input connections, refer inverter manual.

Remove if needed the finger protection polycarbonate plate by releasing screws behind the module. Connect Mains in, AC load wires, alarm and GND wires to screw terminals of MBP. Fasten the finger protection plate to original position.

### 4.1 Static switch input

Static switch AC output is internally wired to Manual bypass. No cable connections needed.

### 4.2 Mains Input connection

Make sure that both mains input and static switch output are switched off from sub-rack before connecting the cables. Connect the mains cable to the screw terminals X1/1-3 (L N PE) according to pin configuration on the frame's rear panel. Use 1-phase power cable cross-section 3 x 0.75 ... 10,0mm<sup>2</sup>. **Use a maximum 40A fuse (MCB with C-curve) to protect the wiring and the static switch. There is no internal fuse in the static switch and no internal disconnecting device.**

### 4.3 Load connection

Make sure that both mains input and static switch output are switched off from sub-rack before connecting the cables. Connect the load cable/cables to the screw terminals X2 (1L-1N-1PE, 2L-2N-2PE, 3L-3N-3PE) according to pin configuration on the frame's rear panel. Use 1-phase power cable cross-section 3 x 0.75 ... 10,0mm<sup>2</sup>. The internal distribution MCB fuses can be 1 ... 40A B/C curves or optionally 2-pole MCBs or RCDs 30/300mA.

### 4.4 Grounding

Make sure that both mains input and static switch output are switched off from sub-rack before connecting the cables. Connect the Cabin grounding cable to the bolt or PCB's GND screw with M5 ring terminal according to pin configuration on the frame's rear panel. Use cable cross-section 4,0 ... 10,0mm<sup>2</sup>. The external maximum mains fuse is 40A.

### 4.5 Communication bus

Connect the D-connectors of all the inverters, static switch and manual bypass in the system parallel with a flat cable available from the manufacturer. There is a free connector in the cable for connecting a PC for remote monitoring to the system or expanding the cable. PC remote monitoring is also wired through manual bypass to MBP frames' rear panel.

## 4.6 Alarm connection

There are two potential free switch over relay contacts connected through a 6 pole connector. Maximum allowed voltage in the alarm connector is 60 V against the protective ground. Maximum allowed current is 1 A. The plug is included in the package. There is no need to use the inverter alarms. The bypass will alarm also when there is any fault in the inverter system.

See chapter 8 for EMC and ferrite clips included in delivery.

## 5. Operating manual bypass switch

### PROCEDURE

When inverter system is started from OFF mode, the rotating switch is turned clockwise (OFF -> MAINS -> SYNC -> AUTO). When system is turned off this will be done in opposite order (AUTO -> SYNC -> MAINS -> OFF). The switch can't be turned directly from OFF position to AUTO position or vice versa.

Recommendation is to use off-line mode in static switch when operating manual bypass. Do not turn on inverter outputs before manual bypass is turned to normal operating AUTO mode. Static switch will be powered in SYNC mode. Wait minimum 15 seconds in SYNC mode until static switch has started to off-line mode and then turn manual bypass to AUTO mode. Start the inverter outputs when manual bypass is in AUTO mode, see inverter manual for further details. Now the system is set to normal operating mode, where default and backup supplies can be set in static switch parameters.

When system will be turned off, turn off first inverter AC outputs (see inverter manual) in AUTO mode, which forces static switch to off-line mode. Then turn manual bypass counterclockwise to the needed position. Static switch will shut down in MAINS position, but loads will be still powered from direct grid supply without backup. Turn the manual bypass to MAINS position if the static switch needs to be swapped or to OFF position if system will be turned off.

### MANUAL BYPASS ROTATING SWITCH POSITIONS

OFF	No supply No voltage in the output. No mains input for the static switch
MAINS	Mains supply, no backup Mains connected to the output. No mains input for the static switch. Mains mode is typical service mode. In this position the inverter system including static switch is bypassed and AC power is supplied to load directly from mains network.
SYNC	Mains supply, no backup Mains connected to the output. Mains input connected to the static switch, static switch starts-up in this position In Sync mode the supply to loads is still from mains bypassing the inverter system, but now static switch AC input is connected. <u>Wait min. 15 seconds in SYNC mode</u> until static switch starts. Make sure that system is in off-line mode before turning to AUTO mode. Do not start inverter AC outputs yet

**AUTO** Inverter System supply (online/offline), battery backup

Static switch output (automatic selection inverter AC output or mains) connected to the output. Auto mode is the normal operating mode.

In start-up procedure:

Turn on inverter AC outputs. System is ready for normal operating mode

In shut-down procedure:

Turn off inverter AC outputs before turning manual bypass to SYNC position

## 6. Pin configuration and connection circuit of MBP68300 power frame

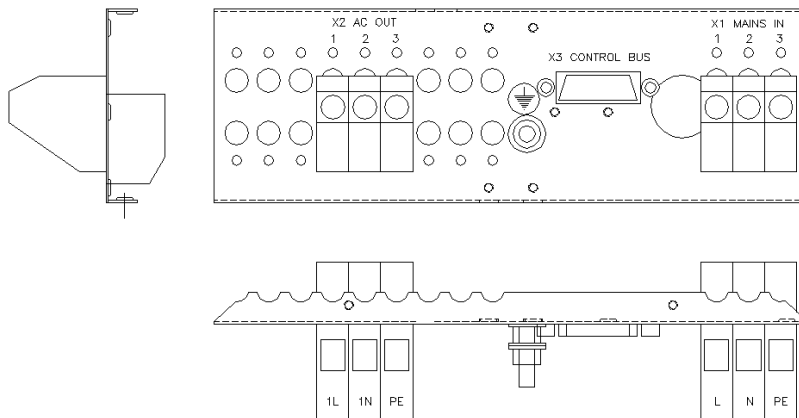
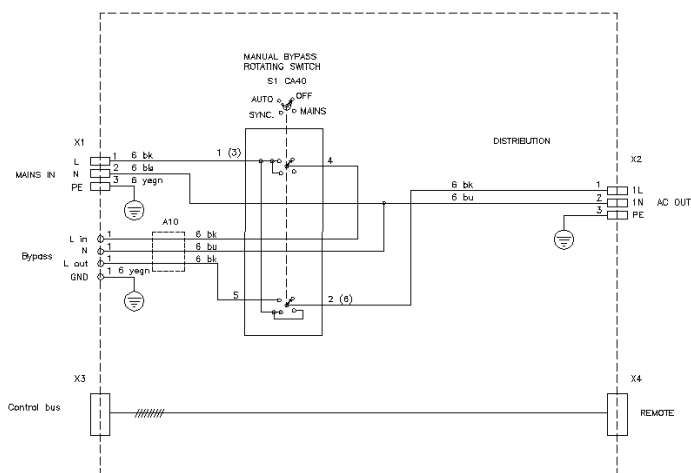

## 7. Pin configuration and connection circuit of MBP68360 power frame

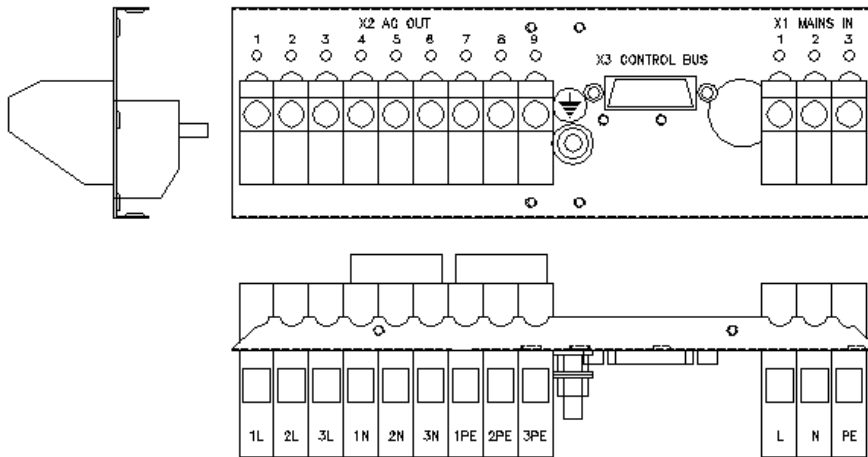
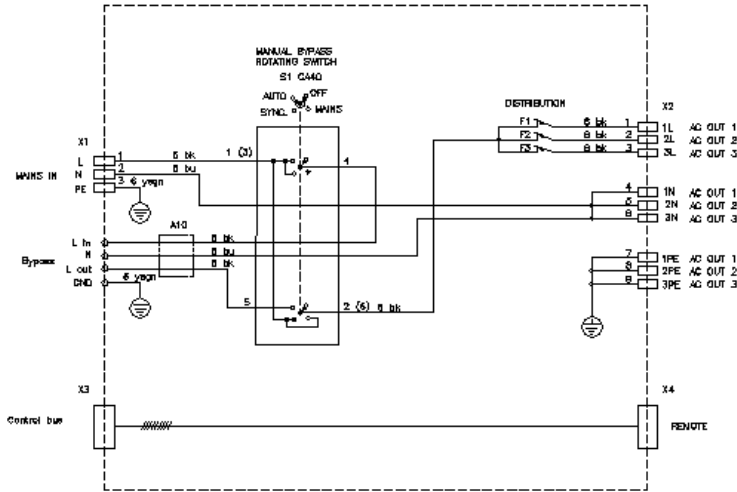

## 8 EMC considerations

Power frames MSR8170 for inverters and MBP68300/MBP68360 for manual bypass and static switch includes EMC ferrites in delivery. Manual bypass power frame includes built-in ferrites for mains input and mains output lines, but ferrites for DC input and alarm lines are not included in power frames.

In order to fulfill EN55022 conductive emissions B-curve limits, external ferrites (incl. in delivery) need to be used in DC input and in alarm relay wires. Ferrites are not needed for A-curve limits. However, if inverter system is a part of the bigger power system, it may be decided case by case if EMC conductive emissions requirements applies for inverter system wires.

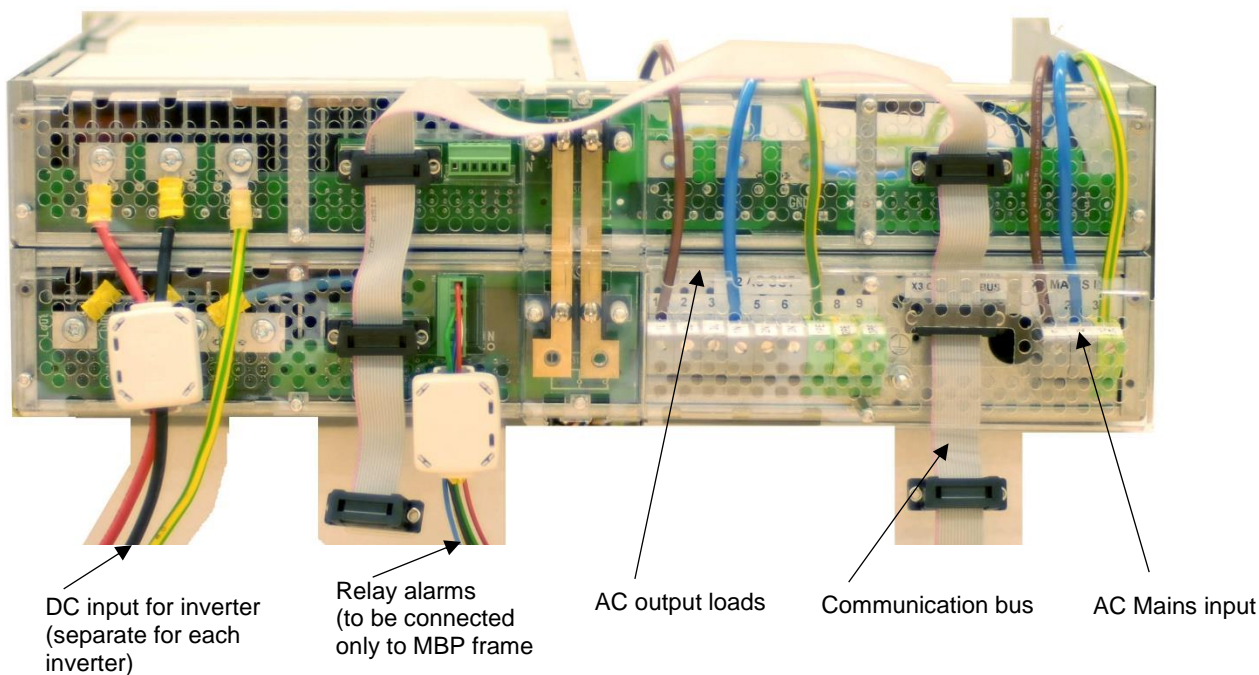

Figure 1. MBP68360 + MSR8170 rear panel wiring with one inverter module  
 External ferrites for DC input and alarm relay wires, AC lines ferrites included in MBP68360 power frame