

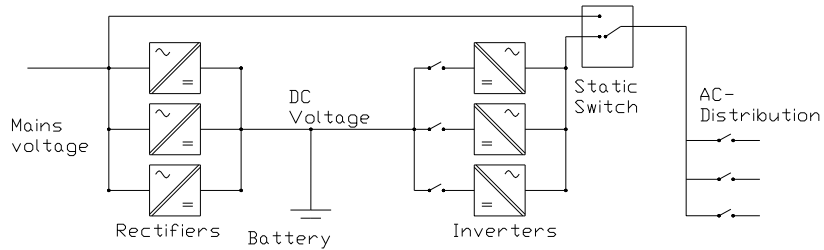

External Static Switch for DAC60000 Inverters



Vertical installation
6U/14TE module



Horizontal installation to 19" 2U panel
AC-distribution and manual bypass can be included to same package

FEATURES

- Small size, light weight, standard 19" rack
- On-line/off-line configurations, user changeable during operation
- Fast switching, user programmable reaction time for optimized system performance
- Large user programmable synchronization range
- Continuous microprocessor based internal monitoring and diagnostics
- Remote monitoring through RS-232 with standard PC

USER PROGRAMMABLE PARAMETERS

- On-line/Off-line configuration
- Minimum and maximum inverter RMS voltage conformity
- Minimum and maximum mains RMS voltage conformity
- Minimum and maximum mains frequency conformity
- Maximum allowed mains frequency change rate
- Load level to return to inverter supply after overload
- Delay to switch to inverters at rapid mains blackout or over voltage (min. 1ms)
- Delay to switch to mains at rapid inverter blackout or over voltage (min. 1ms)

STATIC SWITCH (BYPASS) MODULES								
Type	Nominal Voltage	Frequency Range	Nominal Power	Max continuous Current	Max off-line short time peak current	Cooling	Dimensions Without Handles	Weight
BPU69130VF	230VAC	40-70Hz	6000VA	27A	Limited by mains fuse	Convection	14TE x 6U x 72mm	3kg
MSR7990 + BPU69130VF	230VAC	40-70Hz	6000VA	27A	Limited by mains fuse	Convection	19" x 2U x 372mm	3.5kg
8760039	Power cable between static switch and inverter							
8760038	Parallel connecting cable, 2-6 pcs of inverters or static switch and 1-5pcs of inverters							
	Mains input cable 2m and AC output cable 2m are included in static switch packing							

SPECIFICATION

ELECTRICAL

Operation voltage range	80 - 270 VAC
Synchronizing frequency range	40-70 Hz (user programmable)
Protection, external fuse in mains AC input	MCB 32A B-, C- or D-curve or gG fuse 32A
Efficiency at full load	> 99 % @ 230VAC
Overloading capability (off-line)	Limited by mains fuse

MECHANICAL

Connectors	Inverters up to 5 pcs	ST18
	AC input	AMP Mate-N-Lock
	AC Output	AMP Mate-N-Lock
Enclosure		Steel casing IP20
Environmental temperature		0...45 °C full power
		45...60 °C reduced power

STANDARDS

Safety	EN 60950-1
EMC	EN 55022B, EN61000-6-3, EN61000-6-2 or EN61000-6-1 (EN61000-4-3 radiated immunity according to EN61000-6-1 other immunity standards EN61000-6-2)

ALARMS AND INDICATORS

LED indications	Overload – Fault - Mains failure - Mains in use - Inverter failure - Inverter in use – Synchronized - Communication
Relay alarms	Fault in system Primary supply failure
Remote monitoring through RS-232	

MANUAL BYPASS AND AC-DISTRIBUTION SOLUTIONS

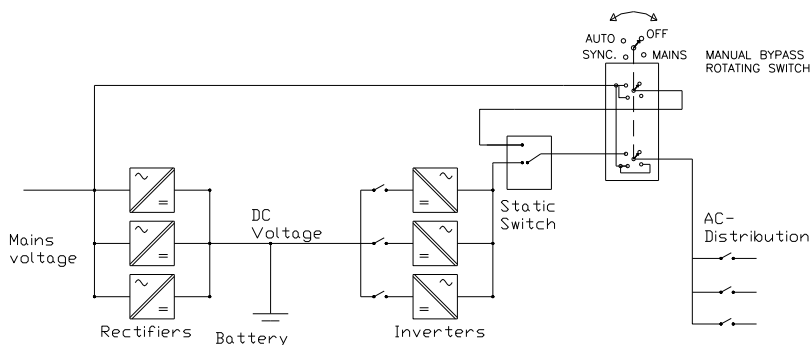

STANDARD MODULES

Enedo's MBP68000 and MBP68200 units offer readymade AC-distribution and manual bypass solutions to build full inverter systems just by choosing needed modules.

CUSTOMISED SOLUTIONS

Customized distribution solutions are also available based on project needs.



COMPLETE INVERTER SYSTEM 19" 6U

MBP68000 fits ideally to be used with DAC60000 vertical 19" 6U model inverters. Complete inverter system including 1...4pcs of inverters (600...4800VA), 6kVA static switch, manual bypass and AC-distribution can be installed to one 19" 6U sub-rack.



HORIZONTAL INVERTER SYSTEM

MBP68200 fits ideally to be used with DAC60000 units in horizontal 19" 2U orientation. Depending on the needed power in the system 1...5pcs of 1000...1200VA inverters can be installed in parallel including external static switch, manual bypass and AC-distribution. MBP68200 and inverters are installed on top of each other in 19" cabinet.

Ordering information: See separate datasheets