



## AC-distribution and Manual Bypass for DAC60000 Inverters



### Modular Construction

6U/14TE  
Mechanics and connectors  
Manual bypass switch

AC-distribution for 3 MCBs  
MCB types can be selected

Due to modular construction the unit can include either the manual bypass or AC-distribution or both of these features.

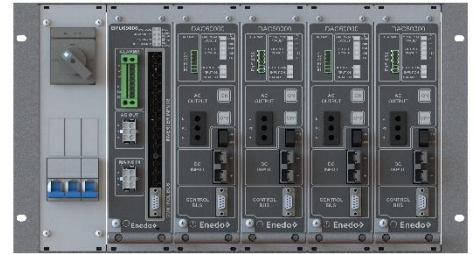

### Complete Inverter System

Complete inverter system including 1...4pcs of inverters (600...4800VA), 6kVA static switch, manual bypass and AC-distribution can be installed to one 19" 6U sub-rack.

- Voltage 100...240VAC · Power rating 6 kVA, max 30A · 4 pole manual bypass rotating switch · 6mm<sup>2</sup> or 10mm<sup>2</sup> screw terminals for mains in and load, 90cm cables for static switch, see details next page

### System level connection circuit:

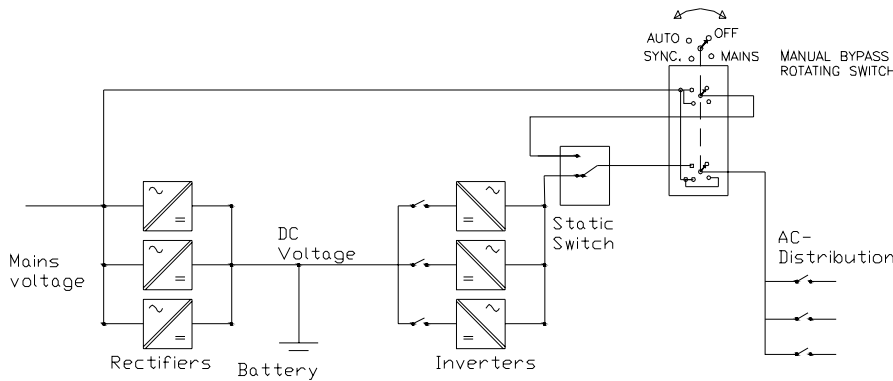

#### Manual bypass switch positions:

- OFF**  
No supply
  - MAINS**  
Mains supply, No mains input for static switch
  - SYNC**  
Mains supply, Mains input connected to static switch
- Note** Recommendation:  
Set the static switch to off-line mode before turning between SYNC and AUTO
- AUTO**  
Inverter System supply on-line or off-line  
Default supply defined in static switch parameters

### MANUAL BYPASS AND AC-DISTRIBUTION TYPE NUMBERS

Type	Description
MBP68000	Manual bypass 6kVA, max 30A, 14TE/6Ux160mm
ADU68030	AC Distribution unit for 3 pcs of output MCBs, 14TE/6Ux160mm Select MCBs from table below, any combination is possible
MBP68060	Manual bypass 6kVA and AC Distribution unit for 3 pcs of output MCBs, 14TE/6Ux160mm Select MCBs from table below, any combination is possible

### MCB ALTERNATIVES

Type / Description	Type / Description	Type / Description	Type / Description
54100100 1A C-curve	54100600 6A C-curve	54101600 16A C-curve	54102500 25A C-curve
54100200 2A C-curve	54101001 10A B-curve	54102001 20A B-curve	54103201 32A B-curve
54100400 4A C-curve	54101000 10A C-curve	54102000 20A C-curve	54103200 32A C-curve
54100601 6A B-curve	54101601 16A B-curve	54102501 25A B-curve	54104001 40A B-curve

## MBP68000 CONNECTION CIRCUIT AND PIN CONFIGURATION

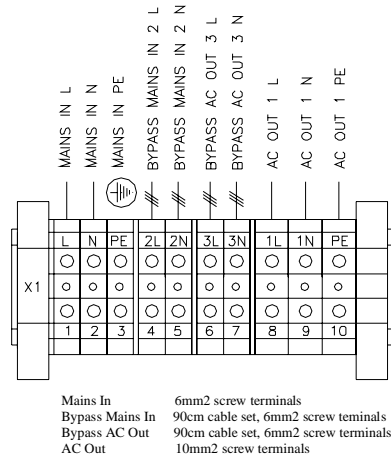
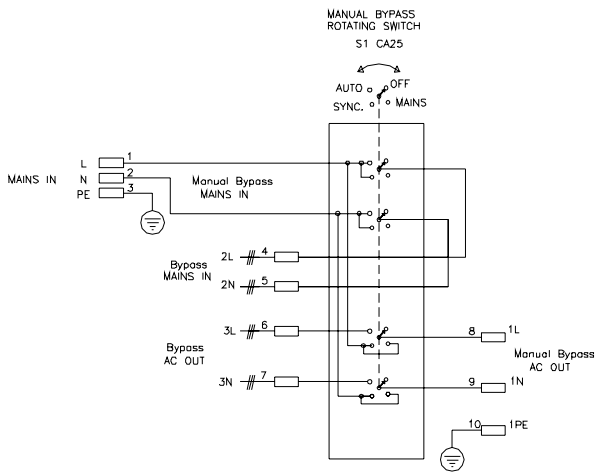

## ADU68030 CONNECTION CIRCUIT AND PIN CONFIGURATION

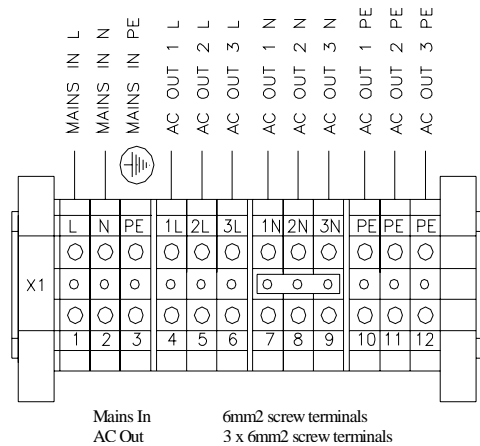
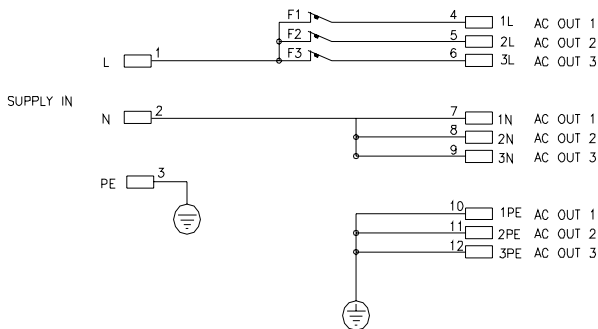

## MBP68060 CONNECTION CIRCUIT AND PIN CONFIGURATION

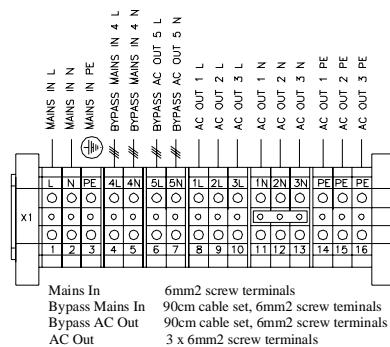
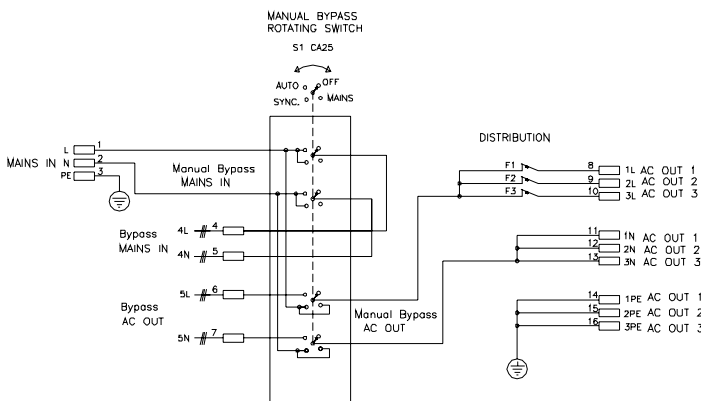

## Specification

### CONNECTIONS

Voltages $U_e$	98...132 VAC 196...264 VAC	3000VA/3000W 6000VA/6000W
Current $I_n$	Nominal current	30A
Frequency		45...65Hz
Safety		According to EN60950, Class I
Mains input connector	L N PE	3-pole 6mm <sup>2</sup> screw terminal
Static Bypass connectors	2L-3L 2N-3N or 4L-5L 4N-5N	2x2-pole 6mm <sup>2</sup> screw terminal
AC outputs connector	1L-3L 1N-3N 1PE-3PE	3x3-pole 6mm <sup>2</sup> screw terminal
	All connectors are located on rear panel	
Mains supply fuse	max 32A	External
Wiring	4-6 mm <sup>2</sup>	Halogen-free, 105°C

### CONTROLS

Manual bypass switch	Rotating switch K&N CA25 , 4 positions	max current 32A, short circuit max 450A
Distribution	1-3pcs of MCB MCB safety switches	On front panel, 1A-25A B or C curve

### MECHANICAL

Dimensions	Height Width Depth	6U (263mm) 14" (70mm) 160mm (+ switch 30mm)
Weight	Module	2,26 kg
Enclosure	hot galvanized steel	IP20
Front plate painted		RAL7035
Finger protection terminals		Polycarbonate plate in front of screw

### ENVIRONMENTAL

Temperature range	Operating Storage	-25°C...+50 °C -40°C...+70 °C
Grounding	6mm <sup>2</sup> screw terminal	1+3pcs on rear panel

## Operating and connecting the Manual bypass

### General

MBP68000 series is manual bypass switch and/or AC-distribution unit for Enedo inverter systems. By manual bypass AC loads can be supplied directly from mains bypassing the inverter system. The inverter system can be also totally switched off by manual bypass switch. In normal operation mode (AUTO) inverter supply is distributed to loads via manual bypass. Also 1...3pcs of AC-distribution fuses can be included to MBP unit (MBP=manual bypass).

Three different variants are available:

1. MBP68000 Manual bypass switch without AC-distribution
2. ADU68030 AC-distribution unit without manual bypass
3. MBP68060 Manual bypass and AC-distribution unit

### Connecting the cables

Remove the finger protection polycarbonate plate by releasing two screws behind the module. Connect Mains in and AC load wires to screw terminals of MBP. Make the strain relief by cable ties and fasten the finger protection plate to original position.

### Mains connection

Connect the mains cable to the screw terminals 1-3 (L N PE) according to pin configuration on the MBP's rear panel via the strain relief. Fasten the cable by cable tie to the holder located beside the screw terminal. Use 1-phase power cable cross-section  $3 \times 0.75 \dots 6,0\text{mm}^2$ . The external maximum mains fuse is 32A. Make sure that both mains input and bypass output are switched off from sub-rack before connecting the MBP.

### Load connection

Connect the load cable to the screw terminals 8-16 (L N PE) according to pin configuration on the MBP's rear panel via the strain relief. Fasten the cable by cable tie to the holder located beside the screw terminal. Use 1-phase power cable cross-section  $3 \times 0.75 \dots 6,0\text{mm}^2$ . The external maximum mains fuse is 32A. Make sure that both mains input and bypass output are switched off from sub-rack before connecting the MBP.

### Connection the Bypass input and output

Use pre-assembled MBP's 90cm bypass Mains in and AC out cables or similar 2m cables delivered with the static switch. Connect (if not pre-assembled) the "mains in" cable to the screw terminals 4-5 and "ac out" cable to the screw terminals 6-7 in the MBP's rear panel via the strain relief. Fasten cables by cable tie to the holder located beside the screw terminal. Connect pre-assembled MBP's "mains in" and "AC out" cables to static switch unit's mating connectors on front panel.

### Mounting the units

The module is mounted to the 19" sub-rack by 4pcs of M2,5 screws from the front panel.

### Operating manual bypass switch

#### PROCEDURE

When inverter system is started from OFF mode, the rotating switch is turned clockwise (OFF -> MAINS -> SYNC -> AUTO). When system is turned off this will be done in opposite order (AUTO -> SYNC -> MAINS -> OFF). The switch can't be turned directly from OFF position to AUTO position or vice versa.

Recommendation is to use off-line mode in static switch when operating manual bypass. Do not turn on inverter outputs before manual bypass is turned to normal operating AUTO mode. Static switch will be powered in SYNC mode. Wait minimum 15 seconds in SYNC mode until static switch has started to off-line mode and then turn manual bypass to AUTO mode. Start the inverter outputs when manual bypass is in AUTO mode, see inverter manual for further details. Now the system is set to normal operating mode, where default and backup supplies can be set in static switch parameters.

When system will be turned off, turn off first inverter AC outputs (see inverter manual) in AUTO mode, which forces static switch to off-line mode. Then turn manual bypass counterclockwise to the needed position. Static switch will shut down in MAINS position, but loads will be still powered from direct grid supply without backup. Turn the manual bypass to MAINS position if the static switch needs to be swapped or to OFF position if system will be turned off.

## MANUAL BYPASS ROTATING SWITCH POSITIONS

OFF	<p>No supply</p> <p>No voltage in the output. No mains input for the static switch</p>
MAINS	<p>Mains supply, no backup</p> <p>Mains connected to the output. No mains input for the static switch.</p> <p>Mains mode is typical service mode. In this position the inverter system including static switch is bypassed and AC power is supplied to load directly from mains network.</p>
SYNC	<p>Mains supply, no backup</p> <p>Mains connected to the output. Mains input connected to the static switch, static switch starts-up in this position</p> <p>In Sync mode the supply to loads is still from mains bypassing the inverter system, but now static switch AC input is connected. <u>Wait min. 15 seconds in SYNC mode</u> until static switch starts.</p> <p>Make sure that system is in off-line mode before turning to AUTO mode. Do not start inverter AC outputs yet.</p>
AUTO	<p>Inverter System supply (online/offline), battery backup</p> <p>Static switch output (automatic selection inverter AC output or mains) connected to the output. Auto mode is the normal operating mode.</p> <p>In start-up procedure: Turn on inverter AC outputs. System is ready for normal operating mode.</p> <p>In shut-down procedure: Turn off inverter AC outputs before turning manual bypass to SYNC position.</p>