

ARTESYN M-CRPS CSU3200AT SERIES

12 V Distributed Power System



Advanced Energy's Artesyn CSU front end series is designed to provide a flexible power conversion solution for compute, storage, and networking equipment in the modular hardware common redundant power supply (M-CRPS). The 3200 W model is in the standard 1 U x 73.5 mm x 185 mm form factor. The series of power supply can cover cost-sensitive entry level systems, or power hungry applications where there are space constraints.

DATA SHEET

Front-end Bulk Power

Total Output Power

3200 W

Input Voltage

90 to 127 VAC, 180 to 264 VAC,
 240 VDC

SPECIAL FEATURES

- Ultra-high density
- 1U power supply
- Active power factor correction
- EN61000-3-2 harmonic compliance
- Inrush current control
- 80PLUS® Titanium efficiency
- N+N, N+1 redundant
- Hot-pluggable
- Active current sharing
- PMBus® compliant
- Closed loop throttle
- Cold redundancy
- Two-year warranty

COMPLIANCE

- Conducted/Radiated EMI Class A Limits
- RoHS
- IEC 60950/62368

SAFETY

- UL/cUL
- CB Test Certificate
- CE Mark
- KC
- EAC
- BIS
- CQC
- BSMI



ELECTRICAL SPECIFICATIONS

Input						
Input Voltage Range and Output Power	90 to 127 VAC 180 to 264 VAC	1400 W 3200 W				
Max Input Current	100/200 VAC	16 A				
Frequency	47 to 63 Hz					
Efficiency	96.0% peak, titanium efficiency rating					
Inrush Current	35 Apk, cold start					
Conducted EMI	Class A					
Radiated EMI	Class A					
Power Factor	>0.9 beginning at 10% load					
Hold-up Time	11 ms at full load					
Leakage Current	<0.583 mA					
Output						
	Main DC Output			Standby DC Output		
	MIN	NOM	MAX	MIN	NOM	MAX
Nominal Setting	-0.20%	12.2 V	0.20%	-3.5%	12.0 V	+3.5%
Total Output Regulation Range	-5%	-	+5%	-5%	-	+5%
Dynamic Load Regulation Range	-5%	-	+5%	-5%	-	+5%
Output Ripple	-	-	1%	-	-	1%
Output Current	1.0 A ¹	-	262.3 A	0.1 A	-	3.5 A
Current Sharing	±2% of total average			TBD		
Capacitive Loading	2,000 µF	-	70,000 µF	270 µF	-	4,700 µF
Output Rise Time	10 ms	-	70 ms	10 ms	-	70 ms

¹ Minimum current for transient load response testing only. Unit is designed to operate and be within output regulation range at zero load.

ENVIRONMENTAL SPECIFICATIONS

Operating Temperature	-5 to 55°C full rated power allowable up to TBD°C short term operation
Operating Altitude	Up to 10,000 feet ¹
Operating Relative Humidity	+5% to 95%, non-condensing
Non-operating Temperature	-40 to +70°C
Shipping and Storage Relative Humidity	+5% to 95%, non-condensing
Non-operating Altitude	Up to 50,000 feet
Vibration and Shock	Standard operating/non-operating random shock and vibration
RoHS Compliance	Yes
MTBF	>400 k hours at 40°C
Operating Life	Minimum of 5 years at 55°C, 80% load, nominal input

¹ Safety creepage/clearance rated for 5,000 m altitude for CQC.

MECHANICAL OUTLINE

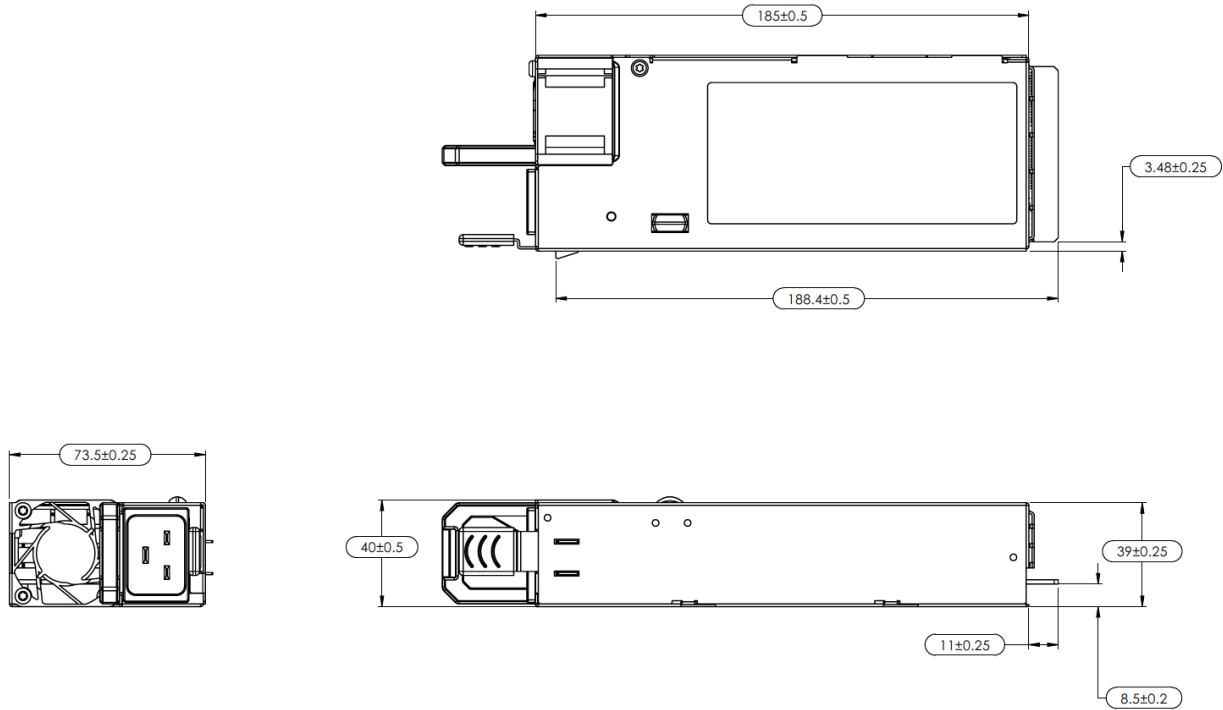

ORDERING INFORMATION

Model Number	Description	Outputs		Airflow Direction
		12.2 V/262.3 A	12.0 V/3.5 A	
CSU3200AT-3-3M0	1U x 73.5 x 185 mm 3200 W, Titanium efficiency			Forward

CONNECTOR DEFINITION

Connector Type	On Power Supply	Recommended Mating Connector
AC Input Connector	IEC320-C20	IEC320-C19
Output Connector	Card-edge	FCI Amphenol 10147875-001LF

Output Connector Pin Configuration ¹			
A1-A9 (P1-P3)	POWER GND	B1-B9 (P7-P9)	POWER GND
A13-A18 (P5-P6)	+12V	B13-B18 (P11-P12)	+12V
A19 (S1)	SDA	B19 (S8)	A0 (digital or analog addressing)
A20 (S2)	SCL	B20 (S9)	A1 (addressing)/DSSI
A21 (S3)	PSON#	B21 (S10)	12VSB
A22 (S4)	SMBAlert#	B22 (S11)	CR_BUS
A23 (S5)	RETURN_SENSE/PS_KILL	B23 (S12)	ISHARE
A24 (S6)	+12V REMOTE SENSE	B24 (S13)	IMON
A25 (S7)	PWOK	B25 (S14)	VINOK

Note 1 - Pin name format is "regular connector (high power connector)".

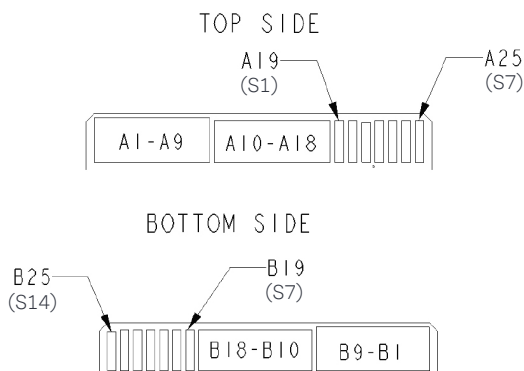

ADDRESSING

PMBUS			
A1	A0	Write Address	Read Address
0	0	B0h	B1h
0	1	B2h	B3h
1	0	B4h	B5h
1	1	B6h	B7h

IPMI FRU			
A1	A0	Write Address	Read Address
0	0	A0h	A1h
0	1	A2h	A3h
1	0	A4h	A5h
1	1	A6h	A7h



ABOUT ADVANCED ENERGY

Advanced Energy (AE) has devoted more than four decades to perfecting power for its global customers. AE designs and manufactures highly engineered, precision power conversion, measurement and control solutions for mission-critical applications and processes.

Our products enable customer innovation in complex applications for a wide range of industries including semiconductor equipment, industrial, manufacturing, telecommunications, data center computing, and medical. With deep applications know-how and responsive service and support across the globe, we build collaborative partnerships to meet rapid technological developments, propel growth for our customers, and innovate the future of power.

PRECISION | POWER | PERFORMANCE | TRUST

Specifications are subject to change without notice. Not responsible for errors or omissions. ©2024 Advanced Energy Industries, Inc. All rights reserved. Advanced Energy®, AE® and Artesyn™ are U.S. trademarks of Advanced Energy Industries, Inc.