



DC/DC converter for railway applications

Description

The PMEL series is the low power model in a new range of highly cost effective, single output converters for chassis mounting. The range is fully compliant with the latest European standards for railway equipment, including EMC and fire and smoke.



Special features include:

- Ultra-wide input voltage range
- Ultra compact, lightweight and cost effective
- Very high efficiency
- Fully compliant with rail standards, including EN 50155 (2021) & EN 50121.3.2 (2016)



Part number	Output	
	V _o [Vdc]	I _o [A]
PMEL 1200	12	6.2
PMEL 1500	15	5.0
PMEL 2400	24	3.1

Input specifications

Parameter	Detail
Input voltage (continuous)	16.8 – 137.5Vdc
Short term supply under / over voltages (< 2 s)	14.4 – 154Vdc
Input Ripple	To EN 50155
Input Protection	Reverse polarity protection Surges and transients to EN50155 (direct and indirect)
Inrush Current	To EN50155
Efficiency	at 110V input 90% typical at 24V input 87% typical
Supply interruptions	EN 50155 Class S2 (10ms interruptions) with low impedance source (input short)
Input fuse	7A PCB mounted fuse. Fitted for safe unit protection in the case of catastrophic failure or reverse polarity connection. Factory replacement only.



Powering Business Worldwide

Output specifications

Parameter	Detail
Maximum output power	75W
Output versions	Single output only
Output voltage	See table
Setting tolerance	±1.0% at 50% load, 15°C to 25°C
Minimum load	Zero
Start-up delay (typical)	<500ms (at any input voltage)
Remote sensing	Not fitted
Maximum output variation	±1.0% combined line & load regulation
Temperature coefficient	<0.02% / °C
Output ripple	<1% Pk-Pk of Output Voltage
Output noise	<75mV Pk-Pk superimposed (up to 20MHz)
Response time	0.5ms to within 1% (for a 10% - 100% load change)
Current limit	Operates at 105 - 130% of rated output current
Thermal protection	Shuts down PSU if safe internal temperature is exceeded. Auto recovery.
Indicators	Green 'Output OK' LED on cover
Output monitoring	Volt solid state relay. Contacts close when output within limits. Absolute maximum contact rating: 250Vdc, 120mA.
Maximum capacitive load (output model dependant)	Output model: 12V 15V 24V Capacitance: 5,000µF 5,000µF 2,000µF
Isolation	Input to Output 2.0kV ac (tested at 3.0kV dc) Input to Case 1.0kV ac (tested at 1.5kV dc) Output to Case 1.0kV ac (tested at 1.5kV dc)

Environmental details

Parameter	Detail
Operating Temperature	EN 50155 class OT4: -40°C to +70°C (no de-rating). (85°C for 10 minutes.) Base plate is intended for cold wall mounting and must not exceed 85°C for full power operation (90°C during 10 minute over temperature).
Output power de-rating	Above 70°C: 3.0% / °C; 100°C absolute maximum
Storage Temperature	-40°C to +85°C Convection / Conduction.
Cooling	Mounting surface should be thermally rated at ≤4.0°C/W. A thermal mass equivalent to 75g of aluminium is required for 10 minutes operation at 85°C.
Relative Humidity	95% max.
Shock & Vibration	EN 50155 (EN 61373) for mounting in any orientation
Environmental Protection	IP20. PCB is conformal coated

Mechanical characteristics

Parameter	Detail
Construction	Ventilated enclosure: aluminium base, steel cover
Finish	Black powder coat paint
Dimensions (L x W x H)	119 x 73 x 37.5mm (including mounting flanges)
Weight	280g
Connectors	Input: Phoenix contact MSTB 2,5/3-GF-5,08 Output: Phoenix contact MSTB 2,5/5-GF-5,08
Fixings	4 x Ø4.8mm clear holes

Applicable norms

Parameter	Detail
EMC	EN 50155 (2021), EN 50121-3-2 (2016)
Fire & Smoke	EN 45545-2 (2020)
Other	EN 50155 (2021)

Outline drawing

MATERIAL: BASE: AL ALLOY
COVER: STEEL

FINISH: BLACK POWDER COAT (RAL9005)
MATT FINISH (GLOSS LEVEL 30% (±5%))
LOWSMOKE EMI.

WEIGHT: 280g

CONNECTORS:

INPUT: PHOENIX MSTB 2,5/3-GF-5,08

MATING: PHOENIX MSTB 2,5/3-STF-5,08

PINOUT: 1: +IN
2: -IN
3: EARTH

OUTPUT: PHOENIX MST 2,5/5-GF-5,08

MATING: PHOENIX MSTB 2,5/5-STF-5,08

PINOUT: 1: OK1
2: OK2
3: N/C
4: GND
5: +Ve

CUSTOMER FIXING HOLES: Ø 4.8mm 4Pos.

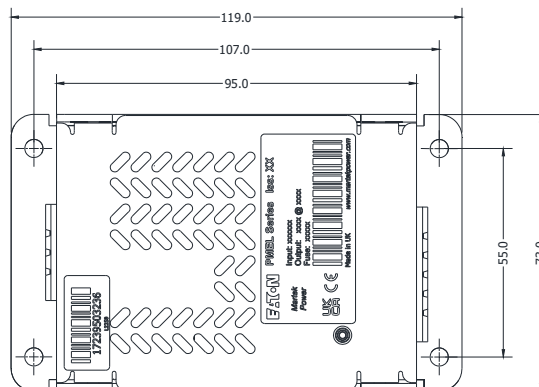

INPUT

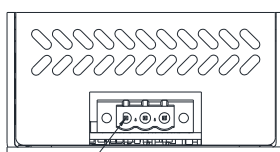

PIN ONE

OUTPUT

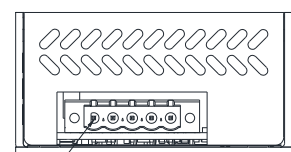

PIN ONE