

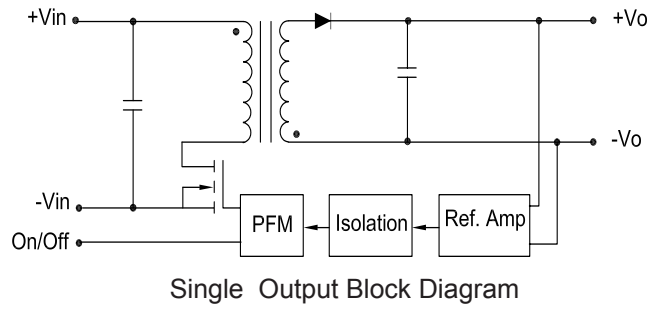



## Block Diagram



## Efficiency Curves

### Single Output

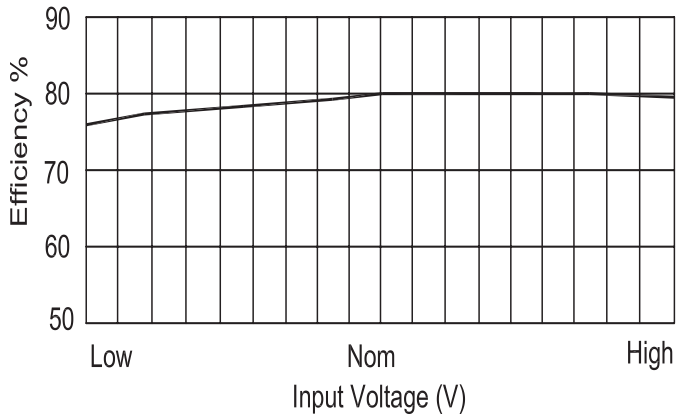

**Efficiency vs Input Voltage**

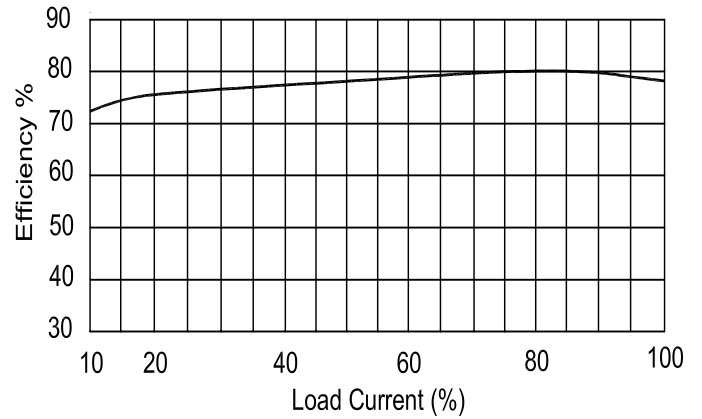

**Efficiency vs Output Load**