







# 40 WATT NCM CHASSIS MOUNT DC/DC CONVERTERS



General Specifications			
All Models			Units
<b>Isolation</b>			
Input to Output Isolation	MAX	1500	VDC
<b>Remote On/Off</b>			
DC/DC On	3.5V - 12V or Open Circuit		
DC/DC Off	0V - 1.2V or Short Circuit		
Control Input Current (On) Vctrl = 5.0v	TYP	0.5	mA
Control Input Current (Off) Vctrl = 0V	TYP	-0.5	mA
Control Common	Referenced to Negative Input		
Standby Input Current Nominal Vin	TYP	2.5	mA
<b>Trim</b>			
Trim Up/Down Range % of nominal output voltage	MIN	±10	%
<b>Environmental</b>			
MTBF - MIL-HDBK 217F @ 25°C	328,000		h
Baseplate Operating Temperature Range	MIN MAX	-40 +100	°C
Storage Temperature	MIN MAX	-55 125	°C
<b>General</b>			
Case Dimension	2.65" x 4.20" x 1.00"		
Unit Weight	345		g
Agency Approvals - Designed to Meet	UL/CUL 60950		

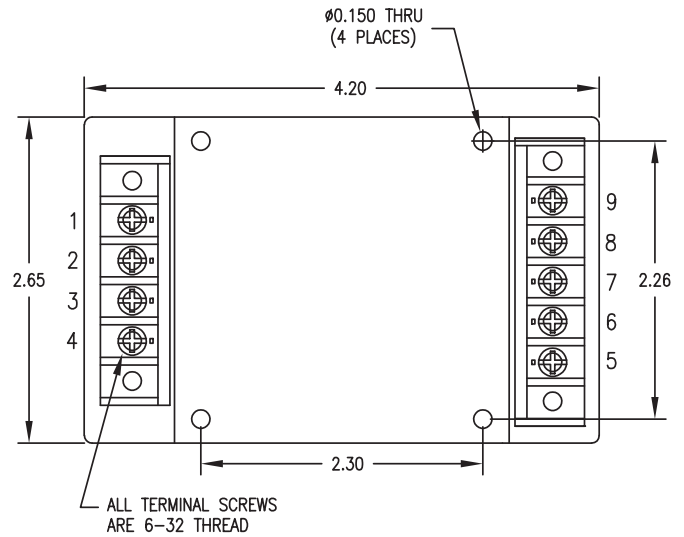

Pin	Name
1	ON/OFF
2	N/U
3	-INPUT
4	+INPUT
5	N/U
6	+OUTPUT
7	-OUTPUT
8	TRIM
9	N/C

TOLERANCE: ALL DIMENSIONS ARE TYPICAL IN INCHES UNLESS OTHERWISE NOTED:	
X.XX	±0.020
X.XXX	±0.005

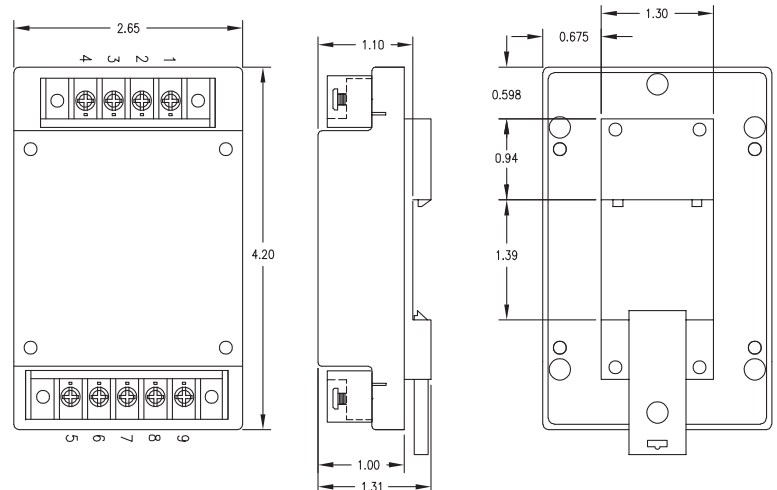

Optional Din Mount

