



40 Watt DRF Chassis Mount DC/DC Single Series

- Efficiency up to 92%
- 4:1 Input Range
- Fully Regulated Output Voltage
- 2500VDC Isolation
- Short Circuit Protection
- Over Voltage Protection
- Remote On/Off
- UL60950 Approved
- RoHS Compliant



Model Number	Voltage			Current			Efficiency @ Max Load (%, Typ)	Capacitive Load Max
	Input		Output	Input		Output		
	Nom. (VDC)	Range	(VDC)	@ No Load (mA)	@ Max Load (mA)	Max (mA)		
DRF40R24S5	24	9 - 36	5.1	90	1889	8000	90	13600 μ F
DRF40R24S12	24	9 - 36	12	90	1850	3300	90	2400 μ F
DRF40R24S24	24	9 - 36	24	90	1856	1670	90	600 μ F
DRF40R24S48	24	9 - 36	48	90	1876	835	89	150 μ F
DRF40R48S5	48	18 - 75	5.1	55	955	8000	89	13600 μ F
DRF40R48S12	48	18 - 75	12	55	915	3300	91	2400 μ F
DRF40R48S24	48	18 - 75	24	55	908	1670	92	600 μ F
DRF40R48S48	48	18 - 75	48	55	928	835	90	150 μ F

FOR DIN MOUNT ORDER OPTIONAL BRACKET DIN-02

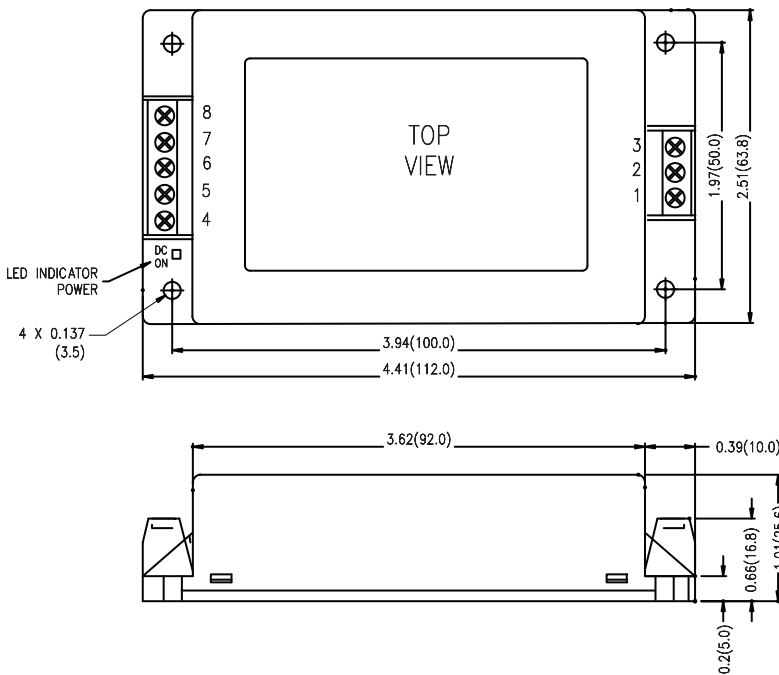

Dimensions are in inches(mm) unless noted
Tolerance: ± 0.02 (± 0.5)

Pin Connections (NC) Not Connected	
Pin	Function
1	Remote On/Off
2	-Vin
3	+Vin
4	+Vout
5	NC
6	-Vout
7	NC
8	NC

