

3 WATT SMT SINGLE



Features

- SMT Technology
- 2:1 Input Range
- Efficiency up to 83%
- I/O Isolation 1500VDC
- Short Circuit Protected
- MTBF > 1,000,000 Hours
- RoHS Compliant
- MSL2 (Moisture Sensitivity Level) per IPC/JEDEC J-STD-020D

Selection Chart					
Model	Input Range		Output		
	Min	Max	VDC	mA	Power W
12S3R3.700SMT	9	18	3.3	700	3
12S5.600SMT	9	18	5	600	3
12S12.250SMT	9	18	12	250	3
12S15.200SMT	9	18	15	200	3
24S3R3.700SMT	18	36	3.3	700	3
24S5.600SMT	18	36	5	600	3
24S12.250SMT	18	36	12	250	3
24S15.200SMT	18	36	15	200	3
48S3R3.700SMT	36	75	3.3	700	3
48S5.600SMT	36	75	5	600	3
48S12.250SMT	36	75	12	250	3
48S15.200SMT	36	75	15	200	3

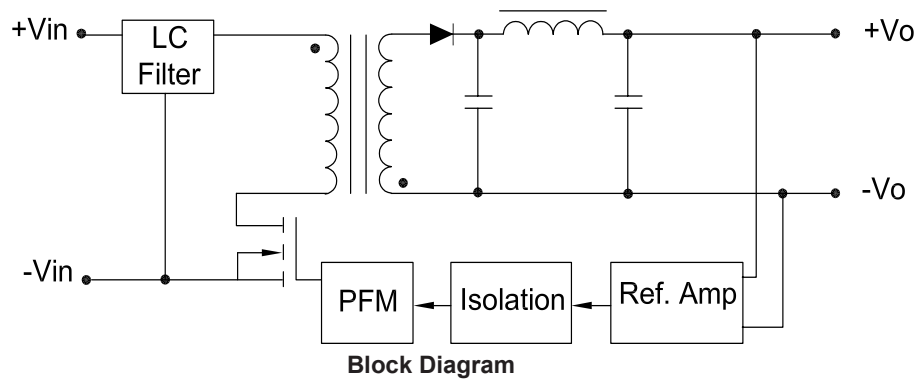

3 WATT SMT SINGLE

Input Parameters							
Model		12S3R3.700SMT	12S5.600SMT	12S12.250SMT	12S15.200SMT	Units	
Voltage Range	MIN TYP MAX	9.0 12.0 18.0				VDC	
Input Current	No Load Full Load	TYP TYP	20 257	20 316	20 305	20 305	mA
Reflected Ripple	TYP	25				mA	
Under Voltage Shutdown	MAX	8				VDC	
Reverse Polarity Input Current	MAX	0.5				A	
Short Circuit Input Power	MAX	1500				mW	
Input Filter		Pi Filter					
Efficiency	TYP	75	79	82	82	%	
Switching Frequency	TYP	300				kHz	
Input Surge Voltage (1000 ms)	MIN MAX	-0.7 25				VDC	
Internal Power Dissipation	MAX	2500				mW	
Recommended Fuse		750 mA Slow Blow Type				mA	
Model		24S3R3.700SMT	24S5.600SMT	24S12.250SMT	24S15.200SMT	Units	
Voltage Range	MIN TYP MAX	18.0 24.0 36.0				VDC	
Input Current	No Load Full Load	TYP TYP	5 127	5 156	5 151	5 151	mA
Reflected Ripple	TYP	15				mA	
Under Voltage Shutdown	MAX	16				VDC	
Reverse Polarity Input Current	MAX	0.5				A	
Short Circuit Input Power	MAX	1500				mW	
Input Filter		Pi Filter					
Efficiency	TYP	76	80	83	83	%	
Switching Frequency	TYP	300				kHz	
Input Surge Voltage (1000 ms)	MIN MAX	-0.7 50				VDC	
Internal Power Dissipation	MAX	2500				mW	
Recommended Fuse		350 mA Slow - Blow Type				mA	
Model		48S3R3.700SMT	48S5.600SMT	48S12.250SMT	48S15.200SMT	Units	
Voltage Range	MIN TYP MAX	36.0 48.0 75.0				VDC	
Input Current	No Load Full Load	TYP TYP	3 63	3 78	3 75	3 75	mA
Reflected Ripple	TYP	10				mA	
Under Voltage Shutdown	MAX	32				VDC	
Reverse Polarity Input Current	MAX	0.5				A	
Short Circuit Input Power	MAX	1500				mW	
Input Filter		Pi Filter					
Efficiency	TYP	76	80	83	83	%	
Switching Frequency	TYP	300				kHz	
Input Surge Voltage (1000 ms)	MIN MAX	-0.7 100				VDC	
Internal Power Dissipation	MAX	2500				mW	
Recommended Fuse		200 mA Slow - Blow Type				mA	

3 WATT SMT SINGLE

Output Parameters						
Models		12S3R3.700SMT 24S3R3.700SMT 48S3R3.700SMT	12S5.600SMT 24S5.600SMT 48S5.600SMT	12S12.250SMT 24S12.250SMT 48S12.250SMT	12S15.200SMT 24S15.200SMT 48S15.200SMT	Units
Output Voltage		3.3	5	12	15	VDC
Output Current	MIN	70	60	25	20	mA
	MAX	700	600	250	200	
Output Voltage Accuracy	TYP	±0.5				%
	MAX	±1.0				
Load Regulation I _o = 20% to 100%	TYP	±0.3				%
	MAX	±1.0				
Line Regulation V _{in} = Min. to Max.	TYP	±0.1				%
	MAX	±0.3				
Ripple & Noise (20MHz)	TYP	50				mV P-P
	MAX	75				
Ripple & Noise (20MHz) Over Line, Load & Temp	MAX	100				mV P-P
Ripple & Noise (20MHz)	MAX	10				mV RMS
Over Load	MAX	120				%
Transient Recovery Time, 25% Load Step Change	TYP	200				µs
	MAX	500				
Transient Response Deviation, 25% Load Step Change	TYP	±2				%
	MAX	±6				
Temperature Coefficient	TYP	±0.01				% / °C
	MAX	±0.02				
Short Circuit Protection	Continuous					

Notes:

- Specifications typical at Ta=+25°C, resistive load, nominal input voltage, full rated output current unless otherwise noted.
- Transient recovery time is measured to within 1% error band for a step change in output load 75% to 100%.
- The 3 Watt SMT Single series has limitation of maximum connected capacitance at the output. The power module may be operated in current limiting mode during start-up, affecting the ramp-up and the startup time. For optimum performance we recommend 4700µF maximum capacitive load.
- When measuring peak-to-peak output noise, use a Cout 0.47µF ceramic capacitor. Scope measurement should be made by using a BNC socket, measurement bandwidth is 0-20MHz. Position the load between 50mm and 75mm from the DC/DC converter.
- Specifications subject to change without notice.
- Water Washability - It is not recommended to use water-wash process on 3W SMT units.
- RoHS Compliance means conformity to EU Directive 2002/95/EC of 27 January 2003, on the restriction of the use of certain hazardous substances in electrical and electronic equipment, lead, cadmium, mercury, hexavalent chromium, polybrominated biphenyls, and polybrominated diphenyl ethers are not present in quantities exceeding the following maximum concentrations in any homogeneous material, except for applicable exemptions. 0.1% (by weight of homogeneous material) lead, mercury, hexavalent chromium, polybrominated biphenyls, polybrominated diphenyl ethers, or 0.01% (by weight of homogeneous material) cadmium. The RoHS marking is as follows.



General Specifications			
All Models			Units
Isolation			
Isolation Voltage, 60 seconds	MIN	1500	VDC
Isolation Resistance, 500VDC	MIN	1000	Mohms
Isolation Capacitance, 100kHz, 1V	TYP	65	pF
	MAX	100	
Environmental			
MTBF (Calculated), MIL-HDBK-217F @ 25°C, Ground Benign	1,000,000		h
Operating Temperature	MIN	-40	°C
	MAX	+85	
Storage Temperature	MIN	-40	°C
	MAX	+125	
Humidity	MAX	95	%
Cooling	Free-Air Convection		
General			
Case Size	1.27 x 0.74 x 0.4 inches 32.3 x 18.8 x 10.2 mm		
Case Material	Non Conductive Black Plastic		
Weight	8.8g		

3 WATT SMT SINGLE

Derating Curve

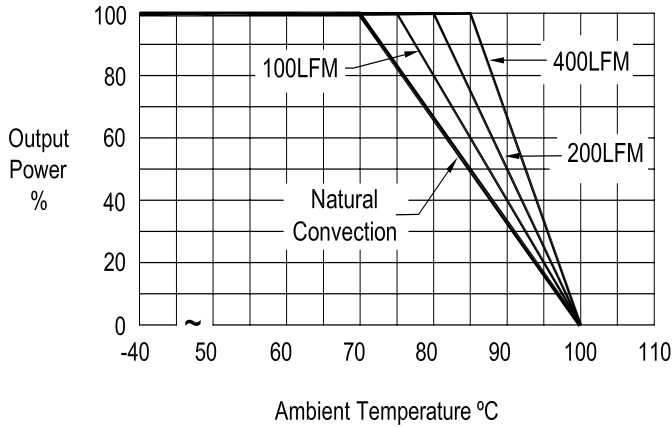

Testing

Input reflected-ripple current is measured with an inductor L_{in} ($4.7\mu H$) and C_{in} ($220\mu F$, $ESR < 1.0\Omega$ at $100kHz$) to simulate source impedance.

Capacitor C_{in} , offsets possible battery impedance. Current ripple is measured at the input terminals of the module, measurement bandwidth is 0-500kHz.

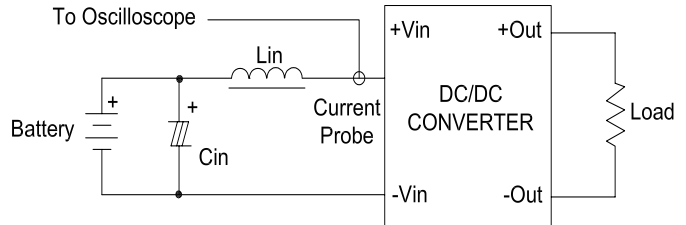

Input Source Impedance

The power module should be connected to a low ac-impedance input source. Highly inductive source impedances can affect the stability of the power module. In applications where power is supplied over long lines and output loading is high, it may be necessary to use a capacitor at the input to ensure startup.

Capacitor mounted close to the power module helps ensure stability of the unit, it is recommended to use a good quality low Equivalent Series Resistance ($ESR < 1.0\Omega$ at $100kHz$) capacitor of $3.3\mu F$ for the 12V input devices and a $1.5\mu F$ for the 24V and 48V devices..

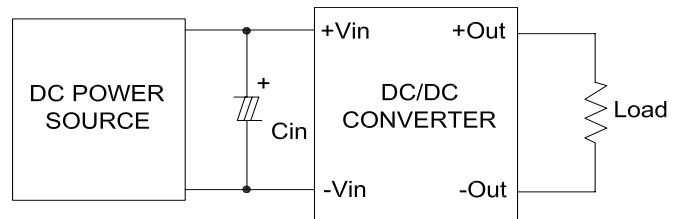

Efficiency vs Input Voltage

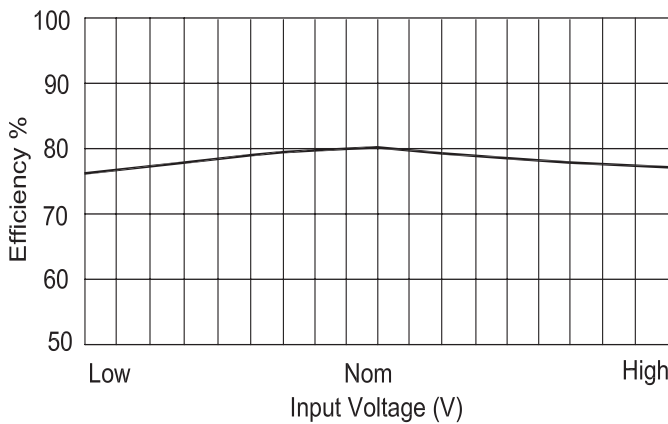

Efficiency vs Output Load

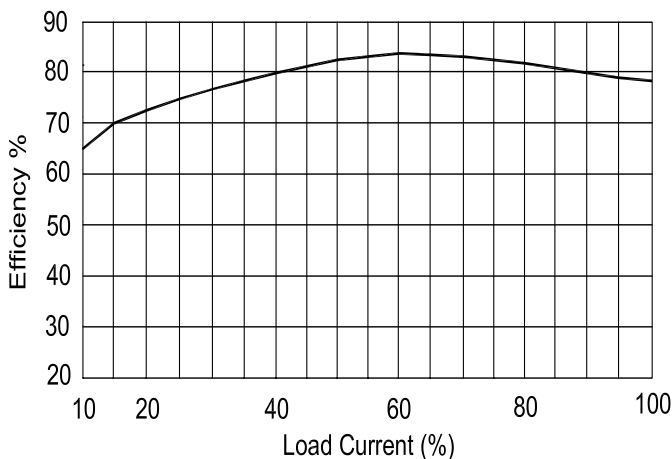

Output Ripple Reduction

A good quality low ESR capacitor placed as close as practicable across the load will give the best ripple and noise performance.

To reduce output ripple, it is recommended to use $3.3\mu F$ capacitors at the output.

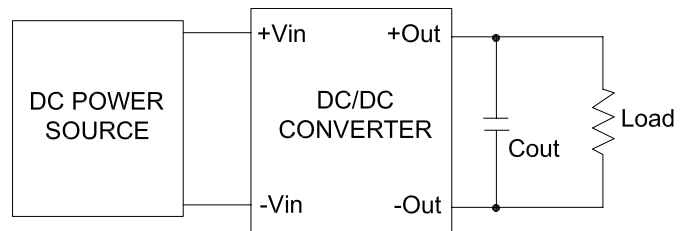

3 WATT SMT SINGLE

Case Mechanical Dimensions inches (mm)

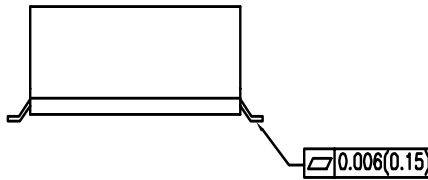
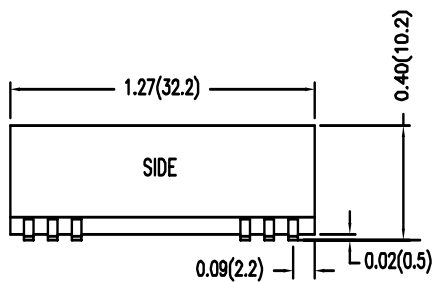
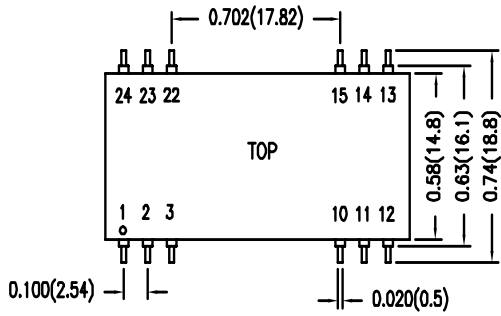

Pin	Name
1	-INPUT
2	-INPUT
3	NC
10	NC
11	NC
12	NC
13	+OUTPUT
14	NC
15	-OUTPUT
22	NC
23	+INPUT
24	+INPUT

TOLERANCE: ALL DIMENSIONS ARE TYPICAL IN INCHES (mm) UNLESS OTHERWISE NOTED:

X.X	±0.01 (0.25)
X.XX	±0.005 (0.13)
PINS	±0.002 (0.05)

Connecting Pin Pattern Dimensions are mm (±0.05)

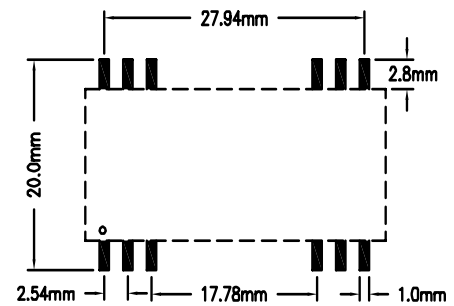

Typical Application

