



Features

- Up to 15 Watts of Output Power
- Wide Input Range
- Rated to 100°C Case Operating Temperature
- 24 & 48 Volt Nominal Inputs, 1.8, 2.5, 3.3, 5, 12 and 15 Volt Outputs
- Water Washable Design
- RoHS Compliant

Description

The Calex BR series are 15 Watt DC/DC converters in a 1" x 2" case with a 4:1 input ratio. The input voltage range is 9 to 36 VDC for 24 Volt models and 18 to 72 for 48 Volt models.

The BR series requires a low source impedance at the input terminals by using an external capacitor (see Application Notes). These models do not have an internal input filter.

The units are filled with a compound which allows them to withstand a normal water wash after being soldered to a PC board.

Selection Chart				
Model	Input Range VDC		Output VDC	Output mA
	Min	Max		
24S1R8.4500BR	9	36	1.8	4500
24S2R5.4500BR	9	36	2.5	4500
24S3R3.4500BR	9	36	3.3	4500
24S5.3000BR	9	36	5	3000
24S12.1250BR	9	36	12	1250
24S15.1000BR	9	36	15	1000
48S1R8.4500BR	18	72*	1.8	4500
48S2R5.4500BR	18	72*	2.5	4500
48S3R3.4500BR	18	72*	3.3	4500
48S5.3000BR	18	72*	5	3000
48S12.1250BR	18	72*	12	1250
48S15.1000BR	18	72*	15	1000

*UL Recognition only applies up to 60VDC

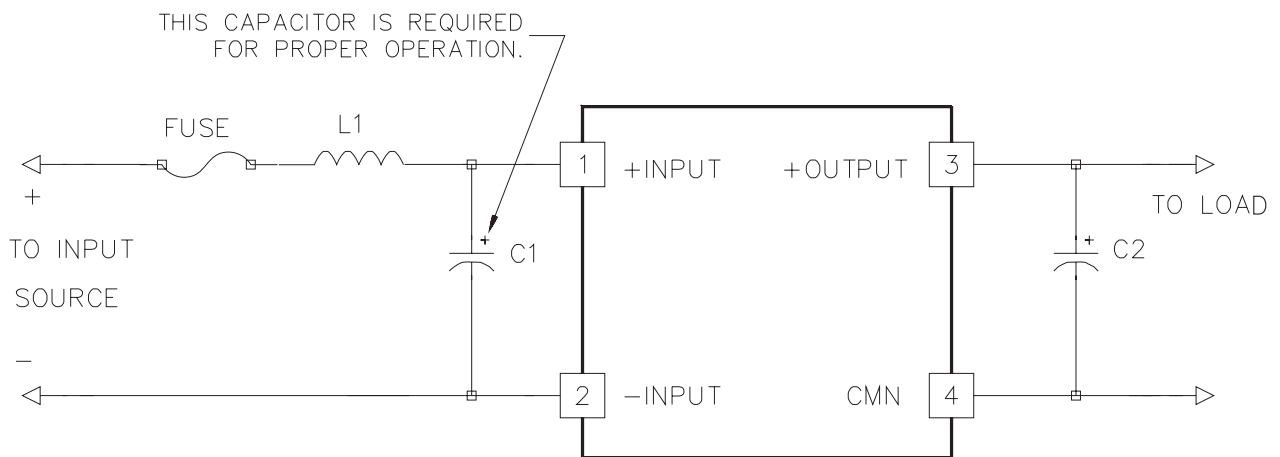

Figure 1. Recommended application

Electrical Characteristics

Unless otherwise specified, all parameters are full load, nominal line, $T_A = 25^\circ\text{C}$, and thermal steady state.

Input Parameters (1)								
Model		24S1R8.4500BR	24S2R5.4500BR	24S3R3.4500BR	24S5.3000BR	24S12.1250BR	24S15.1000BR	Units
Voltage Range	MIN	9						VDC
	NOM	24						
	MAX	36						
Input Current , No Load	TYP	10	10	10	10	10	10	mADC
	TYP	473	630	780	753	744	744	
Efficiency $V_{in}=24\text{VDC}$, Full Load	TYP	72	75	80	83	84	84	%
Switching Frequency	TYP	400						kHz
Maximum Input Overvoltage, 100ms	MAX	40						VDC
Recommended Fuse		(2)						AMPS
Model		48S1R8.4500BR	48S2R5.4500BR	48S3R3.4500BR	48S5.3000BR	48S12.1250BR	48S15.1000BR	Units
Voltage Range	MIN	18						VDC
	NOM	48						
	MAX	72*						
Input Current , No Load	TYP	10	10	10	10	10	10	mADC
	TYP	236	320	385	377	372	372	
Efficiency $V_{in}=48\text{VDC}$, Full Load	TYP	72	75	80	83	84	84	%
Switching Frequency	TYP	400						kHz
Maximum Input Overvoltage, 100ms	MAX	80						VDC
Recommended Fuse		(2)						AMPS

*UL Recognition only applies up to 60VDC

Output Parameters (1)								
Model		24S1R8.4500BR 48S1R8.4500BR	24S2R5.4500BR 48S2R5.4500BR	24S3R3.4500BR 48S3R3.4500BR	24S5.3000BR 48S5.3000BR	24S12.1250BR 48S12.1250BR	24S15.1000BR 48S15.1000BR	Units
Output Voltage		1.8	2.5	3.3	5	12	15	VDC
Output Voltage Accuracy	MIN	1.750	2.450	3.234	4.90	11.76	14.70	VDC
	TYP	1.800	2.500	3.300	5.00	12.00	15.00	
	MAX	1.850	2.550	3.366	5.10	12.24	15.30	
Rated Load Range (3)	MIN	0.68	0.68	0.68	0.45	0.19	0.15	ADC
	MAX	4.54	4.54	4.54	3.00	1.25	1.00	
Load Regulation 1/4 FL - FL	TYP	0.1						%
	MAX	1						
Line Regulation $V_{in} = \text{Min-Max VDC}$	TYP	0.02	0.02				%	
	MAX	0.2	0.1					
Power On Overshoot	TYP	0.5						V
Load Transient Recovery Time (1) error band = $\pm 1\%$	TYP	200						μs
Load Transient Overshoot	TYP	150				300		mV peak
Noise (4) bw = 0.01 - 1MHz bw = 0 - 20 MHz	TYP	100						mV P-P
	TYP	150						
Temperature Coefficient	TYP	50						ppm/ $^\circ\text{C}$
	MAX	150						
Short Circuit Protection, Output to Common		Continuous						

NOTES:

- Refer to the CALEX Application Notes for the definition of terms, measurement circuits, and other information.
Load Transient Overshoot is the output voltage peak amplitude referenced to the final value due to a step load change of 50-75%. "Load Transient Overshoot" and "Dynamic Response" are the same specification. Load Transient Recovery Time is the time for the output to return to within the specified voltage error band centered about the final value. "Load Transient Recovery Time" and "Transient Response" are the same specification.
- See CALEX Application Notes to determine the correct fuse. A fuse is required only for system protection, but must be used for reverse voltage protection of the input.
- Below the minimum rated load, the output may exhibit noise performance degradation. Operation with less than the minimum rated load will not damage unit, and DC regulation is not significantly affected.
- Noise is measured per CALEX Application Notes. Output noise is measured with a 10 μF tantalum capacitor and a 0.01 μF ceramic capacitor connected across the output pins.
- The Case is tied to the -input pin.
- The case thermal impedance is specified as the case temperature rise over ambient per package watt dissipated.
- Specifications subject to change without notice.

NOTES CONTINUED:

- (8) Water Washability - Calnex DC/DC converters are designed to withstand most solder/wash processes. Careful attention should be used when assessing the applicability in your specific manufacturing process. Converters are not hermetically sealed.
- (9) RoHS Compliant
RoHS Compliance means conformity to EU Directive 2002/95/EC of 27 January 2003, on the restriction of the use of certain hazardous substances in electrical and electronic equipment, lead, cadmium, mercury, hexavalent chromium, polybrominated biphenyls, and polybrominated diphenyl ethers are not present in quantities exceeding the following maximum concentrations in any homogeneous material, except for applicable exemptions.
0.1% (by weight of homogeneous material) lead, mercury, hexavalent chromium, polybrominated biphenyls, polybrominated diphenyl ethers, or 0.01% (by weight of homogeneous material) cadmium. The RoHS marking is as follows:



General Specifications				
All Models				Units
Isolation (5)				
Isolation Voltage				
Input to Output 24S	MIN	700		VDC
Input to Output 48S	MIN	1500		
Input to Output Capacitance	TYP	1600		pF
Environmental				
Case Operating Range	MIN	-40		°C
	MAX	100		
Storage Range	MIN	-55		°C
	MAX	125		
Thermal Impedance (6)	TYP	15		°C/Watt
General				
Unit Weight	TYP	1.1		oz
Chassis Mounting Kit		MS8		
MTBF		> 1 M Hours		
Agency Approvals		CSA/UL 60950		

Note: On nominal 48Vin Models UL Recognition only applies up to 60VDC.

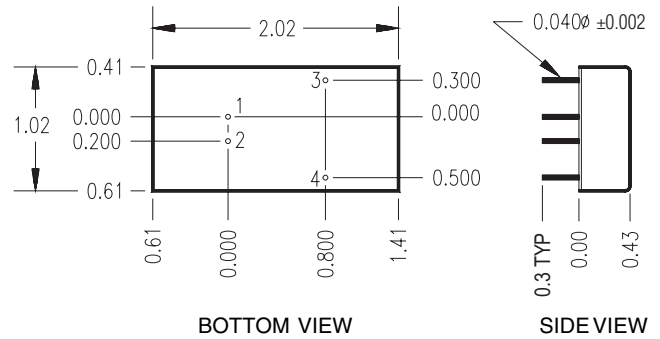

Pin	Function
1	+INPUT
2	-INPUT, CASE
3	+OUTPUT
4	CMN

Mechanical tolerances unless otherwise noted:
X.XX dimensions: ±0.020 inches
X.XXX dimensions: ±0.005 inches
Pin location is for the mating PCB.
The case is metal with a non-conductive header

Application Notes

General

Figure 1 shows the recommended connections for the 15 Watt BR Single. Capacitor C1 is mandatory for proper operation as the BR may be damaged if operated without it. C1 must be rated to handle the ripple current from the BR input. L1 is optional and serves to reduce the reflected ripple current from the BR back into the Input Source. L1 must be rated to handle the DC input current. Information about C1 and L1 is shown in the following paragraphs. The fuse is required only for system protection (Note 2).

Capacitor C2 is optional and serves to further reduce output noise. It may be made up of several capacitors already in your system that are distributed at the loads.

Input Capacitor

C1 in figure 1 is mandatory and must be connected across the input pins for proper operation. Locate C1 within 1" maximum from the input pins.

Suggested Capacitor P/N's:

Model	Type	P/N
24S	Thru hole	470µF, 50V, 0.059 ohms, 2.0A at +85°C (1.2A at +105°C) NIC: NRSZ471M50V12.5X20
24S	SMT	6.8µF, 50V, 0.6 ohms, 0.49A at +85°C. Use 4 in parallel. Vishay Sprague: 593D685X9050D2
48S	Thru hole	68µF, 100V, 0.24 ohms, 1.0A at +85°C (0.63A at +105°C) NIC: NRSZ680M100V10X20
48S	SMT	100µF, 100V, 0.17 ohms, 1.1A at +85°C (0.79A at +105°C) NIC: NACK101M100V16X17

The ripple current and ESR ratings are at 100kHz. Equivalents are available from other manufacturers.

The following table lists the requirements for C1

C1 Requirements:

Model	Input Voltage VDC	Required Capacitor Ripple Current A-RMS, minimum rating
24S	9 to 36	1.8
48S	18 to 72	0.9

Input Inductor

The same inductor is suitable for both 24S and 48S models of the BR.

Suggested Inductor P/N's:

Thru hole	10µH, 4.2ADC, 0.030 ohms. Coilcraft: RFB08010-100
SMT	10µH, 3.5ADC, 0.040 ohms. Coilcraft: DO3340P-103

Equivalents are available from other manufacturers.

Input Filter:

Using an input filter with the values shown gives the following results:

Model	C1	L1	Reflected Ripple Current
24S	Four 6.8µF / 50V Tantalum	10µH	About 50mA P-P About 20mA RMS
48S	100µF / 100V	10µH	About 25mA P-P About 12mA RMS

P-P Reflected Current does not include the switching spike.

The C1 and L1 parts listed above are suitable for the BR operating at full power output. These C1 and L1 parts will work up to +85°C ambient temperature, although the BR itself will require some sort of heatsink or cooling to operate at full power at +85°C ambient. More filtering can be accomplished by increasing the value of C1 and lowering its ESR which is done by paralleling capacitors. In addition adding an optional ceramic capacitor of 0.1 to 1.0µF close to the pins will further help reduce the spike.

Increasing the value of L1 requires at least a proportional increase in the value of C1. i.e. If L1 is doubled then at least double the value of C1 shown in the table. Not using L1 (but MUST have C1) will increase the Reflected Ripple Current back into the the Input Source power supply.

Measurement Technique

Using the ground clip lead on a scope probe will show sharp switching spikes on the oscilloscope, while using a tip jack will minimize this effect. There will generally be a switching spike when scoping the input pins which happens because capacitor C1 cannot be located directly on the BR input pins.