

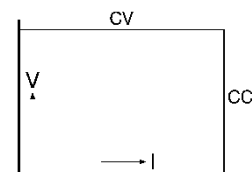

ES 300 - Series 300W DC POWER SUPPLIES

Models	Voltage range	Current range
ES 030-10	0 - 30 V	0 - 10 A



Features

- Very low output ripple and spikes
- EMC surpasses CE requirements:
low emission & high immunity
- High programming speed
- Excellent dynamic response to load changes
- Protected against all overload and short circuit conditions
- Designed for a long life at full power

Functionalities

- Voltage and current control with 10 turn potentiometers
- Master/Slave parallel and series operation with
voltage and current sharing
- 19" rack mounting or for laboratory use
(feet included)
- Optional Remote sensing
- Convection cooling

		ES 030-10
Output		
voltage		0 - 30 V
current		0 - 10 A
Input		
AC single phase, 48 - 62 Hz		92 - 264 V
Input current @ 230 VAC		1.55 A
power factor		> 0.97
full load		
internal fuses		4 AT
standby input power (Vo=Io=0)		6 W
standby input power (Vo=Vmax)		11 W
Efficiency		
AC 230 V input, full load		86 %
AC 115 V input, full load		82 %
Regulation		
Load 0 - 100%	CV	
internal sensing		10 mV
Line 100 - 260 V AC	CV	1 mV
Load 0 - 100%	CC	4 mA
Line 100 - 260 V AC	CC	1 mA
(internal voltage sensing)		
Ripple + noise (full load)		
rms (BW=300 kHz)	CV	5 mV
p-p (BW=20 MHz)	CV	15 mV
rms (BW=300 kHz)	CC	6 mA
p-p (BW=20 MHz)	CC	15 mA
Temp. coeff., per °C	CV	$5 \cdot 10^{-5}$
	CC	$10 \cdot 10^{-5}$
Stability after 1 hr warm-up		
during 8 hrs	CV	$3 \cdot 10^{-4}$
	CC	$10 \cdot 10^{-4}$
$t_{amb} = 25 \pm 1 \text{ °C}$, $V_{in} = 230 \text{ VAC}$		
(internal voltage sensing for CC-stab.)		

Analog Programming	CV	CC
Programming inputs		
input range	0 - 5 V	0 - 5 V
accuracy	$\pm 0.2\%$	$\pm 0.5\%$
offset	-3 ... +10 mV (on 5 V)	0 ... +20 mV (on 5 V)
input impedance	1 MOhm	1 MOhm
Monitoring output		
output range	0 - 5 V	0 - 5 V
accuracy	$\pm 0.2\%$	$\pm 0.5\%$
offset	0 ... +7 mV (on 5 V)	-5 ... 0 mV (on 5 V)
output impedance	1 Ohm / max. 4 mA	1 Ohm / max. 4 mA

Reference voltage on prog. connector	V_{ref} TC	5.165 ±31 mV 12 ppm / 30ppm max.
+12 V output on prog. Connector	V_o R_o	12 V 500 Ohm

Status output CC - status	CC - operation	5 V / 5 mA = logic 1
Remote shutdown Response time		with + 5 V (3.5 - 12V) or relay contact 3 ms
Indicators (front panel)		CV-mode, CC-mode
Controls (front panel)		Mains on/off, CV- and CC-potmeter

Programming speed (resistive load)	ES 030-10	
Rise time (10 - 90%) output voltage step time, (100% load)	0 → 30 V	1 ms
Fall time (90 - 10%) output voltage step time, (100% load)	30 → 5 V	2 ms

	ES 030-10	
Recovery time recovery within time, @ 50 - 100% load step max. deviation @ 230 VAC input voltage	100 mV	50 µs 300 mV
Output impedance CV, 0-100 kHz, $I_o > 0.5A$	< 300 mOhm	

Insulation input / output creepage / clearance	3750 Vrms (1 min.) 8 mm	
input / case output / case	2500 Vrms 600 V DC	
Safety	EN 60950 / EN 61010	
EMC Generic Emission Generic Immunity	EN 61326-1 , class B equipment (for use in domestic establishments) EN 61326-1 , equipment for use in industrial and domestic establishments	
Operating Temperature at full load Above 50 °C	- 20 to + 50 °C derate output current linearly to 20% at 75 °C	
Humidity	max. 95% RH, non condensing, up to 40 °C max. 75% RH, non condensing, up to 50 °C	
Storage temperature	- 40 to + 85 °C	
Thermal protection	Output shuts down in case of insufficient cooling	
MTBF	500 000 hrs	

Hold-Up time (100 - 230 VAC input) Vout = 100% , Iout = 100% Vout = 100% , Iout = 50%	18 ms
	50 ms
Inrush current	Limited with NTC resistor of 16 Ohms cold resistance

ES 030-10	
Series operation max. total voltage Master / Slave operation	600 V with optional external Master / Slave Adapter
Parallel operation max. total current Master / Slave operation	no limit max. 4 units
Remote sensing (optional)	option P185
max. voltage drop per load lead	2 V <i>Note: voltage drop across load leads will subtract from max. available output voltage</i>
Over Voltage Limit (variable)	default 34 V, adjustable from 6...34V with trimmer R402
Potentiometers front panel control with knobs resolution	standard 0.03%
Meters scale voltage scale current accuracy V-meter accuracy A-meter	3.5 digit 0 - 30.0 V 0 - 10.00 A 0.5% + 2 digits 1% + 2 digits

Input Connector	Euro-connector at rear panel 10 Amp / 65 °C IEC320/C14, EN60320/C14
DC Output Terminals	Standard: 4 mm sockets at front-panel Option: screw terminals (0.2-4 mm ²) at rear-panel (sockets at front removed) only combined with remote sensing, option P185.
Programming connector	15 pole D-connector at rear panel (FEMALE)
Cooling	Convection cooling
Enclosure degree of protection	IP20
Dimensions (h x w x d)	52 x 333 x 214 mm
Weight	3.1 kg

CV = Constant Voltage
CC = Constant Current

OVL = Over Voltage Limit

Specifications measured at $t_{amb} = 25 \pm 5 \text{ }^\circ\text{C}$ and $V_{in} = 230 \text{ VAC}$, 50 Hz unless otherwise noted.

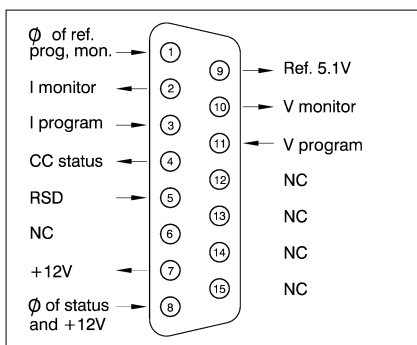

Connections programming connector

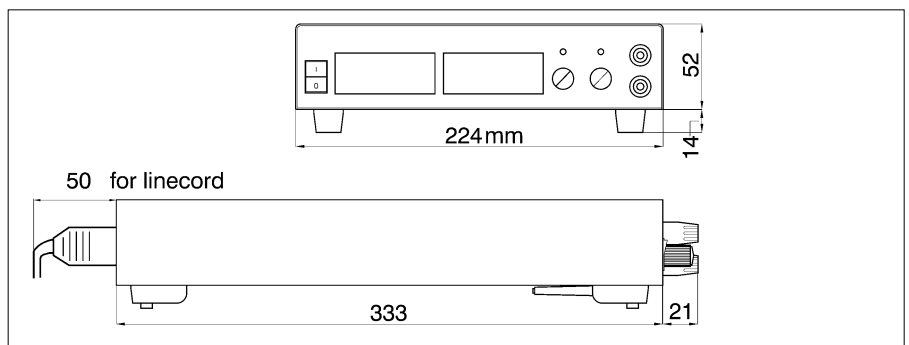

Dimensions

Typical Applications

- Test and measurement
- Controlled battery charging
- Electronic Circuit Development
- Component device testing
- ATE in industrial production lines
- Laboratory analysis
- Medical research equipment
- Accurate current sources

Available Options



Increased Output Power

The conservatively rated unit allows to deliver extra output with the same reliability. At some

derating, either the maximum output voltage or the maximum output current can be increased by about 10%.

- Order Code - P069



Sequencer

Arbitrary Waveform generator or standalone automation. The sequencer is integrated in the Ethernet controller.

- Order Code - P179



Rear Power Output and Remote Sensing

Output terminals at the rear panel instead of bind posts at the front panel, includes remote sensing.

- Order Code - P185



19" Rack Mounting Adapter

Using the 19" mounting adapters, it is possible to position the ES units in a 19" rack. Several configurations possible with multiple ES and / or PSC or ISO AMP modules.



Software control and Interfaces

Interfaces to be installed by factory:

- Ethernet (+ sequencer) - P179
- RS232 controller - P180

External programming interface modules:

- IEEE488 controller module
- ISO AMP module

Notes: 1. Download the special datasheet about Battery Charging from <http://www.DeltaPowerSupplies.com/>.
2. There is only room for one of the interfaces in a unit, see next page for configurations.

19" rack mounting

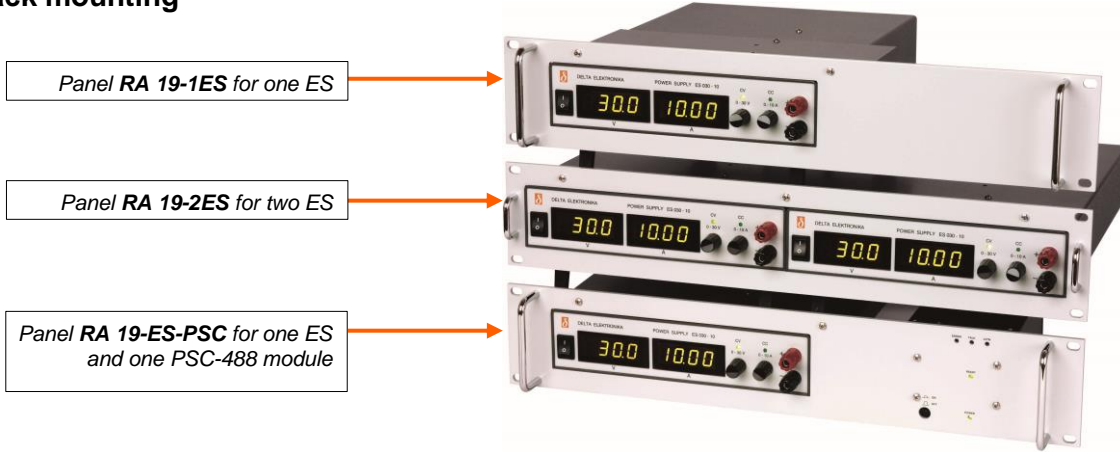

Rear Connections

Standard unit:
Analog programming

Switches Manual / Programming
Analog programming

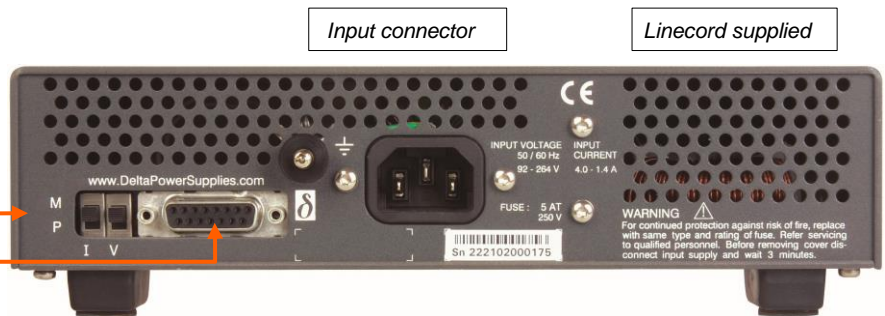

Option P179:
Ethernet programming

Ethernet programming
Switches Manual / Programming
To combine with P185 (=P325)



Option P180:
RS232 programming

RS232 programming
Switches Manual / Programming



Option P185:
Rear power outlet /
Remote sensing

Rear power out / Remote sensing
Switches Manual / Programming
Analog programming

