

FL Series 1.5 kW Regulated DC Power Supplies

750 V to 1500 V Rack Mount

CE Compliant

Fully RoHS Compliant

The FL family of power supplies are sophisticated, 1.5 kW, power supplies with low ripple and noise. They are air insulated, fast response units, with tight regulation.

The FL Series are fully compliant with the Following European Directives:

EN61000-3-2, Line Harmonics
EN61010/ IEC1010, Safety
EN61000-6-4, Conducted and Radiated Emissions
EN61000-6-2:2005, Conducted and Radiated Immunity



Models from 0 to 750 V through 0 to 1500 V, 1.72" H x 19" W x 20" D, 15 lbs.

Features:

Universal Input. Continuous operation over the input voltage range of 90 VAC to 264 VAC, with active power factor correction. (Power is linearly derated to 90 % from 100 VAC to 90 VAC.)

Floating Output. Either output terminal may be grounded for operation as a positive or negative supply.

Embedded Microcontroller control. Front panel digital encoders provide high resolution local adjustment of voltage and current program. Integral RS-232, RS-485, and USB communications provide remote control program and monitor with 12 bit accuracy.

Remote Analog Interface. User selectable 0-5V or 0-10V analog programming and monitors.

Field Strappable Parallel Operation. Up to 4 identical supplies may be operated in parallel with user configurable master and active current sharing.

Zero Space Stacking. 1U rack mount supplies may be stacked with no space required between supplies.

Low Ripple. Ripple is less than 0.05% RMS of rated voltage at full load up to 1 MHz. Total ripple and noise is less 0.2% p-p of rated voltage up to 20 MHz.

Constant Voltage/Constant Current Operation. Automatic crossover from constant-voltage to constant-current regulation provides protection against overloads, arcs, and short circuits.

Constant Current/Current Trip. A rear panel switch allows selection of either current mode.

Cooling. Fan speed control is adjusted automatically as a function of operating temperature. This reduces noise and extends fan life.

Warranty. Standard power supplies are warranted for three years; OEM and modified power supplies are warranted for one year. A formal warranty statement is available.



Designing Solutions for High Voltage Power Supply Applications

GLASSMAN HIGH VOLTAGE INC.

124 West Main Street, PO Box 317, High Bridge, NJ 08829-0317
(908) 638-3800 • Fax (908) 638-3700 • www.glassmanhv.com

GLASSMAN EUROPE Limited (UK)
+44 1256 883007 FAX +44 1256 883017
E-mail: Glassman_europe@glassmanhv.com

GLASSMAN JAPAN High Voltage Limited
+81 45 902 9988 FAX +81 45 902 2268
E-mail: Glassman_japan@glassmanhv.com

Specifications

Input: 90-264 VAC continuous, single-phase, 48-63Hz. The RMS input current at rated power is less than 20 A @ 100 VRMS input and less than 11 A @200 VRMS input. Output power is linearly de-rated from 100% to 90% between 100V and 90V input.

Inrush Current: 30 A max. peak inrush current, 90 to 264 VAC.

Efficiency: 84% typical at full load.

Power factor: 0.99 typical at full load.

Output: Continuous, stable adjustment, from 0 to rated voltage or current by panel mounted optical rotary encoder or by external, user selectable, 0 to +5V or 0 to +10V signals. Voltage accuracy is 0.5% of setting + 0.2% of rated. Current accuracy is 0.5% of setting + 0.2% of rated. Voltage and Current programming ranges are selected by switches that are accessible from the rear panel. Optical rotary encoder resolution: 1V and 1mA with "Fine Adjustment" mode selected. 10 V and 10 mA with "Coarse Adjustment" mode (default).

Static Line Regulation: Better than 0.01% of the Voltage and Current Ratings for 100-132 VAC or 180-264 VAC line variations, under constant load.

Static Load Regulation: Max. 0.05% of Rating for full load to no load variation.

Current Regulation: Better than 0.02% of the rating + 4mA, for short circuit to rated output voltage variation, at any load condition.

Dynamic Voltage Regulation: Typical deviation is 1.5% of rating with recovery to within .5% of rating in 2ms for load transients from 10% to 100% and 100% to 10%.

Ripple and noise (p-p, up to 20 MHz): Max. 0.2% of rated voltage.

Ripple (RMS, 10 Hz - 1 MHz): Max. 0.05% of rated voltage. The ripple and noise are measured at the output connectors of the supply.

Temperature Coefficient: Max. 100 ppm per deg C following 30 minute warm up.

Stability: Max. 0.05% of rated over 8 hours time interval, following 30 minute warm up.

Voltage Rise Time Constant: Typical 45 ms using any of the HV ON, HV enable, local, the remote serial or the remote analog control.

Voltage Decay Time Constant: Typical 45 ms time constant for an equivalent resistive load at the output of 33% of the rated full load.

Polarity: Output is floating and either (DC+) or (DC-) can be connected to chassis ground for reversible polarity. The sum of the output voltage and the float voltage should not exceed 1500 VDC.

Field Strappable Parallel operation: Up to 4 identical units can be connected in parallel providing active current sharing with user configurable master - slave configuration.

Analog Voltage Monitor: User selectable 0 to +5 V or 0 to +10 V, equals 0 to rated, with an accuracy of .5% of reading + 0.2% of rated.

Analog Current Monitor: User selectable 0 to +5 V or 0 to +10 V, equals 0 to Rated, with an accuracy of .5% of reading + 0.2% of rated.

RS232/485 Programming and Monitor Accuracy:

Resolution: 0.025% of full scale for both the voltage and the current channels.

Remote setting accuracy: Voltage setting accuracy is better than 0.5% of setting + 0.2% of rated. Current setting accuracy is better than 0.5% of setting + 0.2% of rated.

Remote reading accuracy: Voltage reading accuracy is 0.5% of reading + 0.2% of rated. Current reading accuracy is 0.5% of reading + 0.2% of rated.

Protection: Automatic current regulation protects against all overloads, including arcs and short circuits. Thermal switches and temperature rise sensing fans protect against thermal overload. Fuses, surge-limiting resistors, and low energy components provide ultimate protection.

External Interlock: Open = off, closed = on.

Front Panel Elements.

Output Voltage Display: 4 Digits / 0.2% \pm 1 count accuracy; 1 V resolution.

Output Current Display: 4 Digits / 0.2% \pm 1 count accuracy; 1 mA resolution.

Indicators: Current Mode, Voltage Mode, Fault, Fine Adjustment, Preset, Remote/Local, HV On.

AC Power: Rocker switch with integral indicator.

Switches (momentary): Baud Rate, Address, Remote/Local, Fine Adjust, Preset, HV On, UVP Adjust, OVP Adjust.

Rotary Encoders: Voltage Adjust, Current Adjust.

Rear Panel Elements. AC power entry terminal strip, AC On indicator, ground stud, HV output connectors, multifunction DIP switch, Analog Interface Connector, RS-232/RS485 connectors, and USB connectors.

Control and Status Signals (II)

Implemented with TTL compatible, 0 to 5.5 V CMOS, positive logic circuitry.

LOC/REM Status: LOW/HIGH indicates Local / Remote Control Mode.

ENABLE/REMA Input: Active in Remote Analog control as HV enable. LOW / HIGH for HV OFF / ON. Logic can be reversed by selected switch on the rear panel.

V/I MODE Status: HIGH / LOW indicates that output is in Voltage/ Current Mode.

LOC/REMA Enable: LOW /HIGH sets the power supply in Local / Remote analog mode.

FAULT Status: Active HIGH, indicates a fault condition. Logic can be reversed by selected switch on the rear panel. The continuously monitored faults are: Input Undervoltage, Over Temperature, Over Voltage, Over Current, Interlock and (optional) Arc Fault.

HV Status: LOW /HIGH indicates that HV output is OFF/ ON.

Environmental:

Operating Temperature: 0 to +40 deg C, full load.

Operating Humidity: < 90% RH (no condensation).

Storage Temperature: -20 to +70 deg C.

Storage Humidity: < 95 % RH (no condensation).

Altitude: For operation above 6500 ft and up to 10,000 ft. MAX, de-rate the output current linearly from 100% to 80% of rated.

Cooling: Forced air cooling with internal fans.

Dimensions (W X H X D): 19" X 1.72" X 20". Refer to the outline drawing.

Weight: 15 lbs (6.9 kg)

AC Input Connector: Screw Terminal Block, Phoenix P/N 1703034 and Housing for cable strain relief.

Output Connectors: 2 high voltage, self locking , Alden connectors, VI21B. Mating connectors, VI31B, attached to 10 ft of 22AWG high voltage wire are provided. Steel housings provides safety protection for both the AC input and the HV connectors.

Withstand Voltage and Insulation (HI-POT):

Input to Output: 2500 VAC RMS,

Input to Ground: 2000 VAC RMS,

Output to Ground: 2500 VAC RMS,

Input to SELV: 2000 VAC RMS,

Output to SELV: 2500 VAC RMS,

Customer Serial Interface to

FL GND: 1000 VAC RMS.

Options

Arc Quench: An arc quench feature provides sensing of each load arc and quickly inhibits the HV output for approximately 20 ms after each arc.

Arc Count: Internal circuitry senses the number of arcs caused by external load discharges. If the rate of consecutive arcs exceeds approximately 2 arcs per second for at least five arcs, the supply will turn off for approximately 2.5 seconds to allow clearance of the fault. After this period, the supply will return automatically to the programmed output voltage value with the voltage rise time constant indicated. If the load fault still exists, the above cycle will be repeated

SS - Slow Start Ramp: Specify standard times of 5, 10, 15, 20, or 30 seconds, ±20%.

Models

MODEL	VOLTAGE (V)	CURRENT (A)	STORED ENERGY (J)	RIPPLE AND NOISE MAX. (P-P)
FL0750F2.0	750	2.0	2.80	1.5V
FL1000F1.5	1000	1.5	5.00	2V
FL1250F1.2	1250	1.2	6.25	2.5V
FL1500F1.0	1500	1.0	6.75	3V

Outline

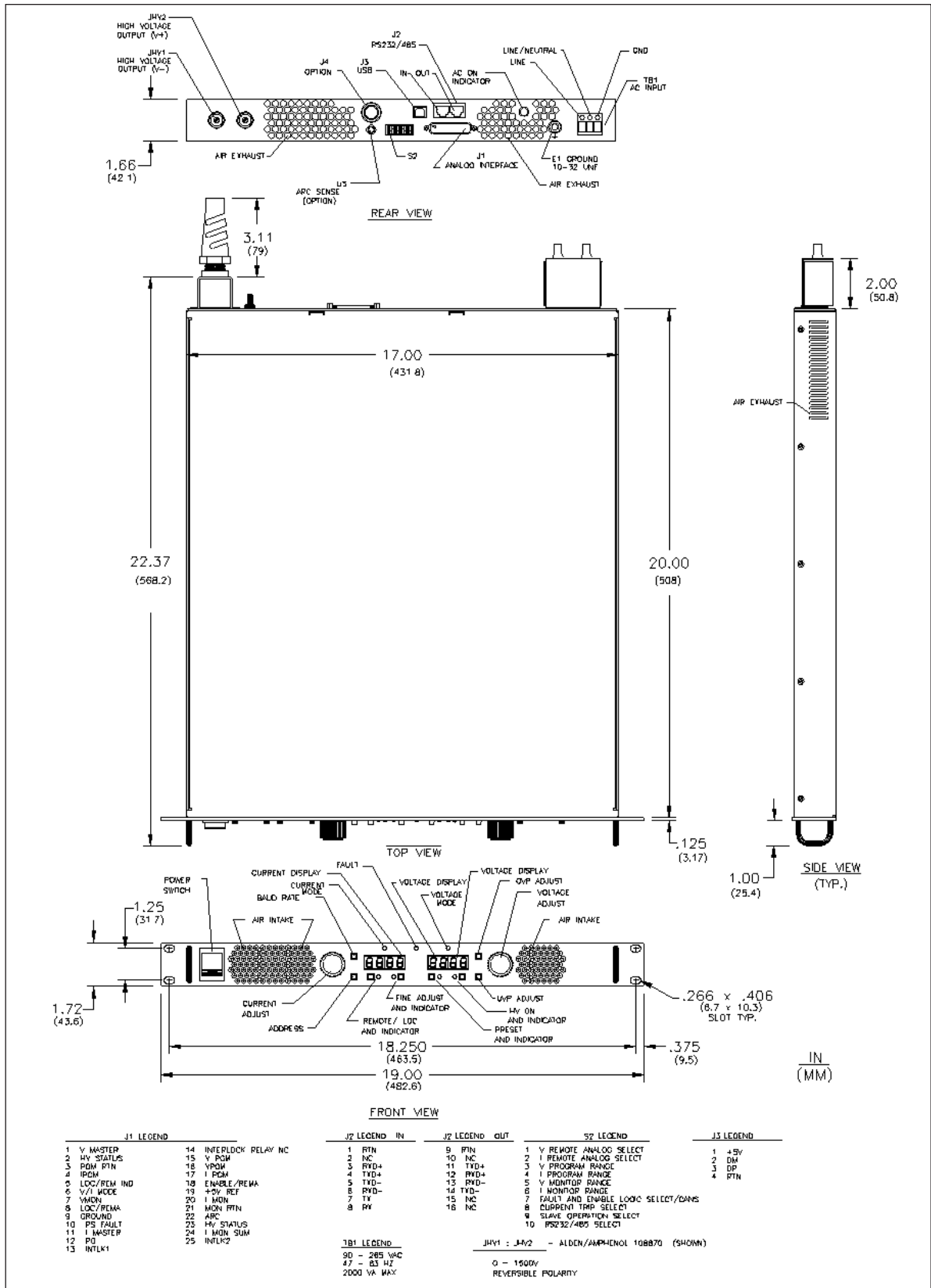

Designing Solutions for High Voltage Power Supply Applications

GLASSMAN HIGH VOLTAGE INC.

124 West Main Street, PO Box 317, High Bridge, NJ 08829-0317
(908) 638-3800 • Fax (908) 638-3700 • www.glassmanhv.com