

MTWA11 SERIES

10W Wall Mount Power Supply for I.T. Equipment



- Wide Input Voltage 90 to 264 VAC, 47 to 63Hz
- European type 2 prong plug
- Output Voltage Available From 5VDC Thru 48VDC
- Optional Output Connector (See appendix)
- Single Output
- Class II Insulation
- CEC Level V, Energy Star 2.0, and RoHS Compliance

1 Year Warranty

Approvals:      

Single Output

| Product Number | Output Voltage | Max. Output Current | Total Regulation | Maximum Output Power |
|----------------|----------------|---------------------|------------------|----------------------|
| MTWA11-S02 | 5 ~ 6 VDC | 1.60 ~ 1.33 A | 5% | 8W |
| MTWA11-S03 | 6 ~ 8 VDC | 1.33 ~ 1.00 A | 5% | 8W |
| MTWA11-S04 | 8 ~ 11 VDC | 1.25 ~ 0.91 A | 5% | 10W |
| MTWA11-S05 | 11 ~ 13 VDC | 0.91 ~ 0.77 A | 5% | 10W |
| MTWA11-S06 | 13 ~ 16 VDC | 0.77 ~ 0.63 A | 5% | 10W |
| MTWA11-S07 | 16 ~ 21 VDC | 0.63 ~ 0.48 A | 3% | 10W |
| MTWA11-S08 | 21 ~ 27 VDC | 0.48 ~ 0.37 A | 3% | 10W |
| MTWA11-S09 | 27 ~ 33 VDC | 0.37 ~ 0.30 A | 3% | 10W |
| MTWA11-S10 | 33 ~ 40 VDC | 0.30 ~ 0.25 A | 3% | 10W |
| MTWA11-S11 | 40 ~ 48 VDC | 0.25 ~ 0.20 A | 3% | 10W |

The total regulation on model S02-S05 is required to use AWG#20/4FT output cable.
 The total regulation on model S06-S10 is required to use AWG#24/4FT output cable.
 The regulation and efficiency will be changed by modified output cable.

Electrical Characteristics

| Parameter | Test Conditions | Min. | Typ. | Max. | Unit |
|---------------------------------|---|-------|------|------|------|
| Input Voltage | Operating Voltage | 90 | | 264 | VAC |
| Input Frequency | | 47 | | 63 | Hz |
| Output Power Range | Vin=90 to 264VAC | 0 | | 10 | W |
| Input Current (Low Line) | Io=Full load, Vin=115VAC | | | 0.3 | A |
| Input Current (High Line) | Io=Full load, Vin=230VAC | | | 0.2 | A |
| Low Line Inrush Current | Io=Full load, 25°C, Cool start, Vin=115VAC | | 35 | 40 | A |
| High Line Inrush Current | Io=Full load, 25°C, Cool start, Vin=230VAC | | 70 | 80 | A |
| Efficiency | Io=Full Load, Vin=230VAC | 71 | 76 | 85 | % |
| Line Regulation | Io=Full Load | | 0.5 | 1 | % |
| Load Regulation | Vin=230VAC | | 3 | 5 | % |
| Over Voltage Protection | | | Nil | | % |
| Over Current Protection | Nil But, Output protected to short circuit conditions | | | | % |
| Transient Response | Io=Full Load to Half Load, Vin=100VAC | | | 4 | mS |
| Hold-Up Time | Io=Full Load, Vin=110VAC | 5 | 10 | | mS |
| Start Up Time | Io=Full Load, Vin=100VAC | | 2 | 3 | S |
| * Ripple & Noise (Peak to Peak) | Full Load, Vin=90VAC | | 0.5 | 1 | % |
| Safety Ground Leakage Current | Io=Full Load, Vin=240VAC | | 0.2 | 0.25 | mA |
| No-Load Power Consumption | No load, Vin=240VAC | | 0.2 | 0.3 | W |
| Temperature Coefficient | All output | -0.04 | | 0.04 | %/°C |

Conditions

| Parameter | Test Conditions | Min. | Typ. | Max. | Unit |
|---|-----------------|------|------|------|-------|
| Operating Temperature | | 0 | 40 | 70 | °C |
| Storage Temperature | | -40 | | 85 | °C |
| Relative Humidity | No-Condensing | 5 | | 95 | % |
| Operating Temperature at 25°C, Calculated per MIL-HDBK-217F | | 0.1 | | | M Hrs |
| De-rate linearly from 100% load at 40°C to 50% load at 70°C | | | | | |

Approvals and Compliance

| Parameter | Test Conditions | Min. | Unit |
|--|----------------------|------|-------|
| Dielectric Withstanding Voltage for Primary to secondary | Primary to secondary | 4242 | VDC |
| EMI requirements for CISPR-22 | Vin=220VAC | B | CLASS |
| EMI requirements for FCC PART-15 | Vin=110VAC | B | CLASS |

Mechanical and PIN out

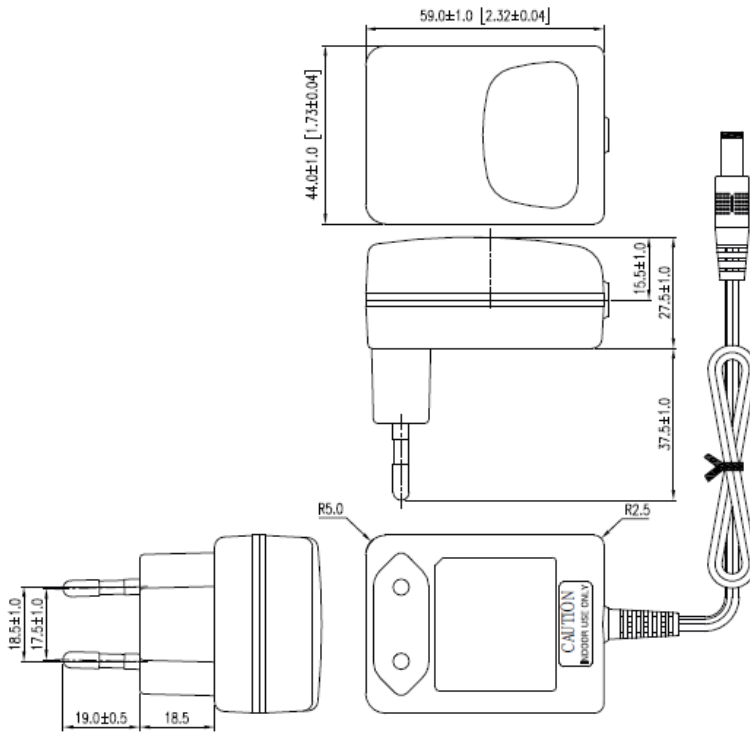

Note:

1. Dimensions are shown in mm.
2. Weight: 90g approx.
3. Optional output connector.