



PST24

Standard product

Features

- ▶ 24, 28, 48Vdc Input voltage ranges (28Vdc for Avionic)
- ▶ 1 to 3 outputs from 2V5 to 48Vdc
- ▶ Up to 240W
- ▶ Extremely low profile 190*90*15mm
- ▶ EMI, Surge and transient protection for defense, avionic applications
- ▶ Conduction cooled 100°C baseplate

Safety IEC/EN 60950-1, RoHS lead-free-solder compliant



Description

The PST24 is a family of very compact DC-DC converter in chassis mount format that provides input filtering, input transient protections, very robust mechanical mounting and connection, optional conformal coating, required in most of the severe environment. **The 28Vdc Input version includes MIL-STD-461E filtering, MIL-STD-704A, MIL-STD-1275, DO-160E input protections for avionic and defense applications.**

Based on the VI-CHIP® PRM and VTM concept from Vicor, this converter provides extremely low profile , high reliability, high efficiency, input-to-output isolation, soft start, overtemperature protection. The inputs are protected against reverse polarity, surges and transients, implement over/undervoltage lockout and EMI filtering. The outputs are continuously short-circuit proof .The 100°C baseplate operation allows operation in high temperature environment.

The output can be configured in many different voltages from 3V3 to 48Vdc , others possibilities are even possible as semi-standard versions.

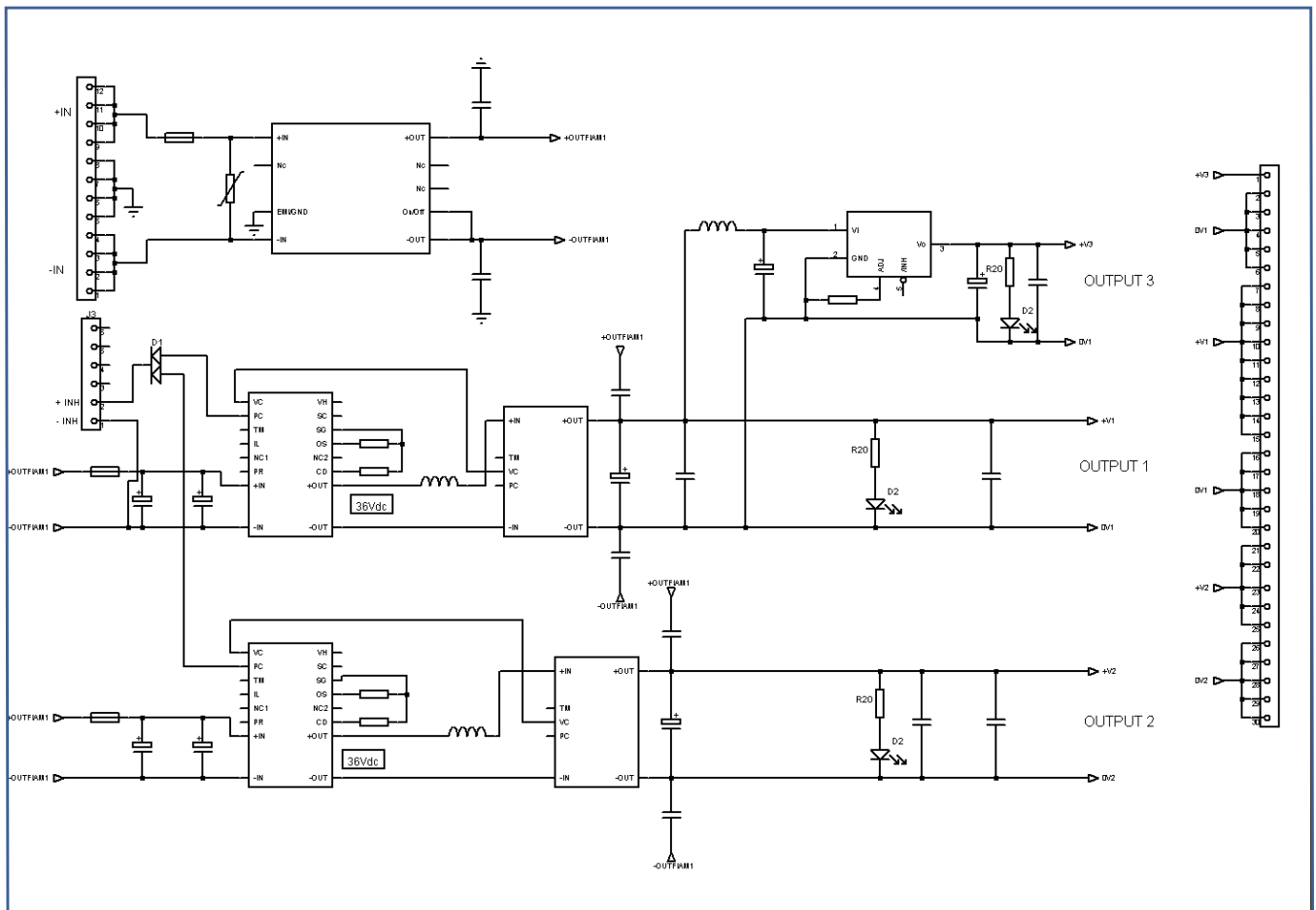



▼ Input

Electrical Input Data

Input		24			28			48			Unit	
Characteristics	Conditions	min	typ	max	min	typ	max	min	typ	max		
Operating input voltage		18	24	50	16	28	50	36	48	75	V	
Input surge	50ms						100				V	MIL-STD-1275A/B/D
	100ms						80			100	V	DO-160E
Undervoltage turn-on			16	17,5		15,9	17		34	35,5	V	17V at 100°C
Undervoltage turn-off		13,5	14,1		12,2	13,5		30	31,8		V	
Overvoltage turn-on		50	52		50	52		75,5	77		V	
Overvoltage turn-off			53	55		53	55		78	82	V	
Input current	Vin min		10	10		10	10		7,8	10	A	
No-load input power				12			12			12	W	
Peak inrush current	Vin nom		35			35					A	
Rise time inrush			10			10					µs	
Start-up time			200			200					ms	

Input Fuse

An internal fuse protects against damages in case of a failure. The fuse is not user-accessible.

Model	Fuse type	Rating	Reference
24V	Bussmann	15A	BK1/MCRW15A
28V	Bussmann	15A	BK1/MCRW15A
48V	Bussmann	15A	BK1/MCRW15A

Input Transient Protection / Electromagnetic Compatibility (EMC)

A VDR (Voltage Dependent Resistor) added with the active input protection and a common mode input filter form an effective protection against input transients.

Input Reverse polarity Protection

A tranzorb diode placed internally across the input will cause the fuse to blow in case of a reverse polarity .

▼ Options Description

-55°C operation (T)

The thermal grade of internal Vicor converter and other components are changed to comply with such low ambient temperature.

Conformal coating (V)

During manufacturing process , when V option is specified, components and pcb are covered with an acrylic coating to address high level of ambient humidity application.

Heatsink option (H) for convection operation

With the H option , a 15mm heatsink with is added on the baseplate for convection or air forced operation . The overall height of the converter is then 30mm.

Waveforms

Typical values for PST2428-12120-12120-NN

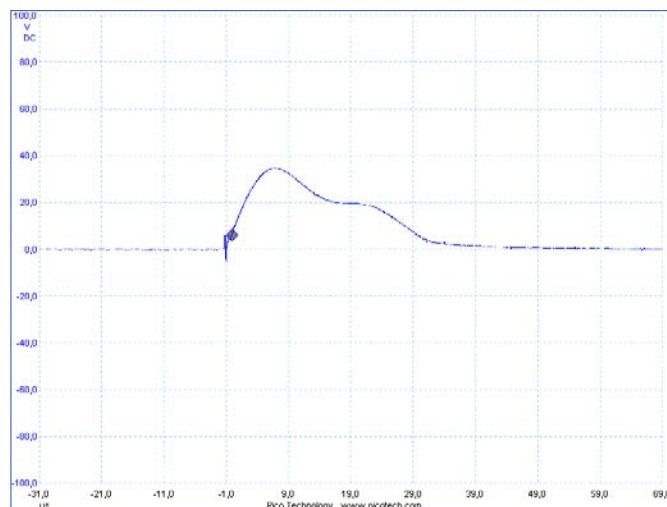

Typical inrush current



Output

Electrical Output Data

General conditions :
25°C ambient.

Output data - V1,V2

Output		2V5			3V3			5V			12V			15V			24V			32V			48V			Unit
Characteristics	Conditions	min	typ	max	min	typ	max	min	typ	max	min	typ	max	min	typ	max	min	typ	max	min	typ	max	min	typ	max	
Output voltage			2V5			3V3			5			12			15			24			32			48	V	
Trim range	Potentiometer	2,2		3,6	2,2		3,6	4		5,6	10,7		16,3	10,7		16,3	20,4		31	27		49	27		49	V
Overvoltage protection				4,6			4,6			6,9			18,3			18,3			36,7			55			55	V
Nominal output current	V1	0	30	30	0	30	30	0	24	24	0	10	11	0	8	11	0	5	5,8	0	3,5	4,4	0	2,5	4,4	A
Nominal output current	V2	0	15	15	0	15	15	0	15	15	0	10	11	0	8	11	0	5	5,8	0	3,5	4,4	0	2,5	4,4	A
Output limit	V1		30A			30A			120W			120W			120W			120W			120W				120W	
Output limit	V2		15A			15A			15A			120W			120W			120W			120W				120W	
Output noise	20MHz		150			150			150			70			180			180			180				180	mVpp
Efficiency			80			80			87			88			88			89			90				90	%
Load Regulation	Vin nom.			4			4			3			2			2			1,5			1,5			1,5	%

Output data - V3 Low power output (V3 is issued from V1 by a point of load regulator)

Output		2V5			3V3			5V			Unit
Characteristics	Conditions	min	typ	max	min	typ	max	min	typ	max	
Output voltage			2V5			3V3			5V		V
Trim range	Potentiometer	2,25		3,8	2,25		3,8	2,25		5,5	V
Overvoltage protection		-		-	-		-	-		-	V
Nominal output current		0	2,25	2,25	0	2,25	2,25	0	2,25	2,25	A
Output current limit				3,5			3,5			3,5	A
Output noise	20MHz		50			50			50		mVpp
Efficiency			88			89			89		%
Load Regulation	Vin nom.			0,4			0,5			0,8	%
V1 value	V3/V1 not isolated	5		18	5		18	6,5		18	

Auxiliary Functions

Primary Inhibit (Remote On/Off)

The inhibit input disables (short circuit between + INH and -INH of J3) or enables (open-circuit between +INH and -INH) the converter. This signal is **not** referenced to the input voltage and will disable/enable all outputs at the same time. In systems consisting of several converters, this feature may be used to sequence the activation of the different converters.

Output Voltage Adjustment

The converter offer adjustment for each output voltage V1,V2,V3 though a potentiometer. (see output data table for voltage range adjustment)

Powergood

Three green leds on the pcb indicates the presence of each output voltage .

Waveforms

Typical values for PST2428-12120-12120-NN

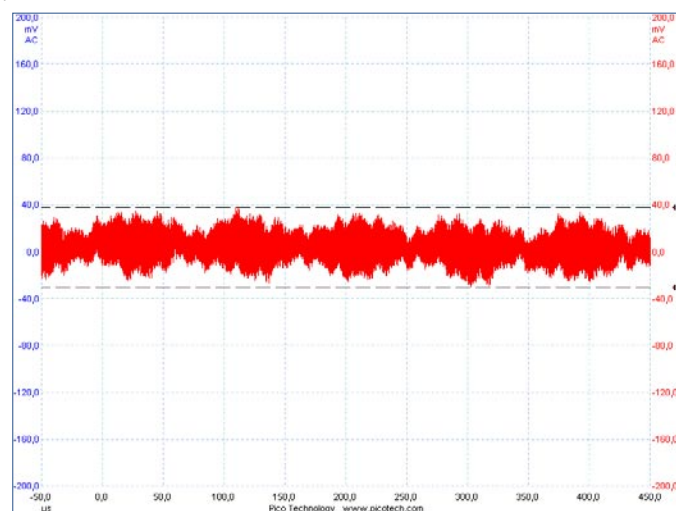

Typical output ripple noise



Parallel and Series Connection

The output V1, V2 can be connected in series to either create a higher voltage output or a positive and negative output configuration. The maximum output current of a serial-connected outputs is limited by the output with the lowest current limit.

Output voltages above 48V (SELV - Safety Extra Low Voltage) require additional safety measures in order to comply with international safety requirements.

Parallel operation is possible with the addition of external diodes in series with each output.

Redundant Systems Operation

When systems require a very high level of reliability and should work normally in the event of a failure, N+1 redundancy is implemented where N is the number of converter to support power requirement. If one converter fail, the remaining ones still deliver the power to the loads.

External diodes are required with the PST24 to ensure proper N+1 operation .

Hold-up time

The converter provides low hold-up time. If a hold-up time is required (some Avionic applications for example) , use external input capacitors of adequate size.

Formula for additional external input capacitor : $C = 2 \cdot P_{out} \cdot t_h \cdot 100 / (V^2 - V_i^2) / n$
whereas :

- C = external input capacitance [mF]
- P_{out} = output power [W]
- n = efficiency [%]
- t_h = hold-up time [ms]
- V_i = minimum input voltage
- V = Input voltage level before interruption

Output Current Limitation

The converter outputs are protected by the power limitation of the pre regulator PRM (approx. 140W), the current limitation is dependent of the output voltage . The output is then stopped and will automatically recover when fault disappear. In case of a quick short circuit, it may be necessary to power off and on the input voltage to restart.

Thermal Considerations

The converter is designed to be mounted on a dissipative area, in conduction cooling mode. The max. operating temperature is the temperature of the baseplate which should not exceed 100°C.

Addition of grease or thermal pad between the converter baseplate and the chassis is mandatory .

Thermal protection

A temperature protection is integrated internally, disabling output when junction temperature exceed 135°C. The converter automatically restart, when the temperature drops below this limit.

Waveforms

Typical values for PST2428-12120-12120-NN

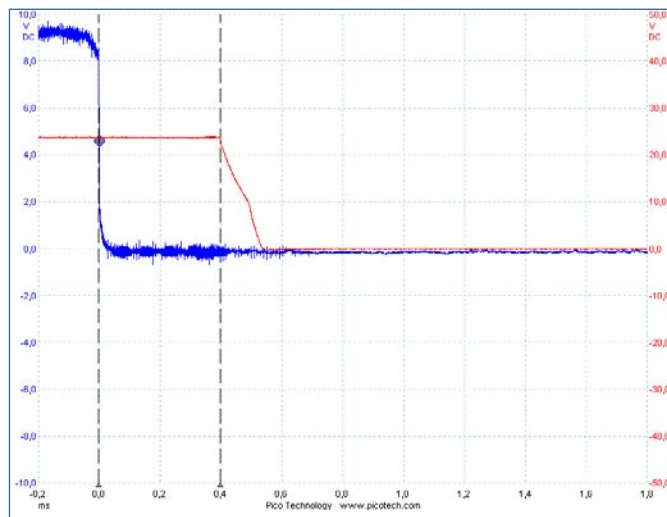
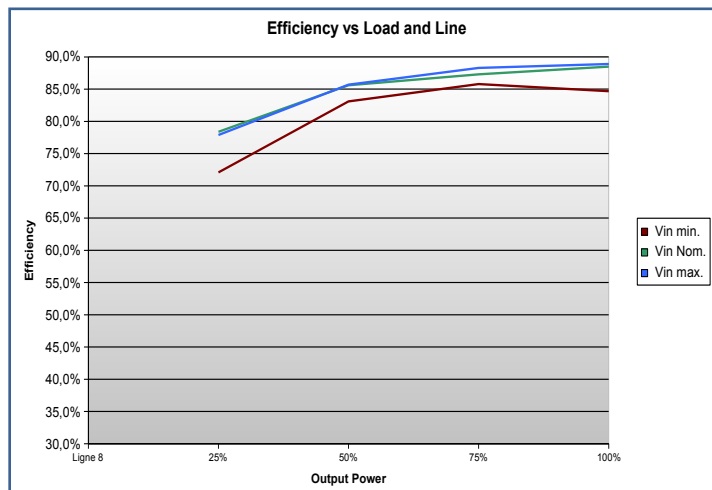

Hold up time

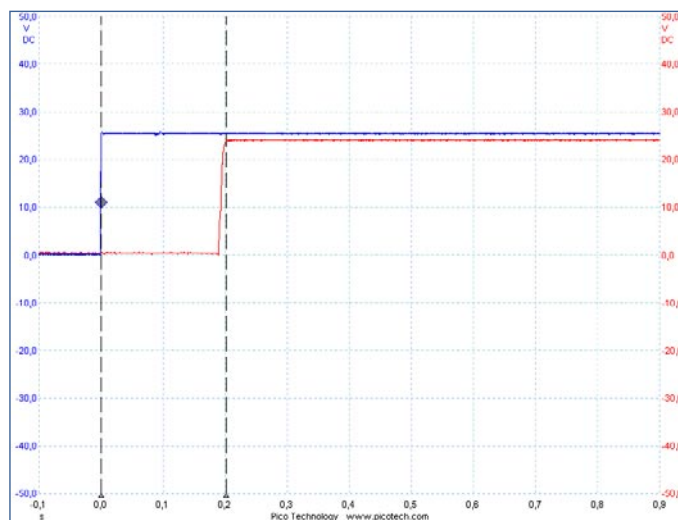

Start up time



▼ Electromagnetic

Electromagnetic Immunity

	Input version	Standard	Level	Value	Waveform	Source imped.
Supply surge	48Vdc	ETS 300		100V	100ms	
Direct transients	48Vdc	ETS 300 386-1		200V	5 / 50 μ s	
	28Vdc	MIL-STD-1275A/B/D		100V	50ms	
	28Vdc	MIL-STD-1275B		250V	70 μ s	
	28Vdc	MIL-STD-704A		70V	20ms	
	28Vdc	DO-160E, sect16		80V	100ms	
Surges	24,28,48 Vdc	EN 61000-4-5	3	2000V	1,2 / 50 μ s	12 ohms
Electrical fast transients/burst	24,28,48 Vdc	EN 61000-4-4	4	4000V	5 / 50 μ s	50 ohms

Electromagnetic Emissions

Level according to EN55022B for PST24,48, according MIL-STD-461E CE101,CE102 for PST2428

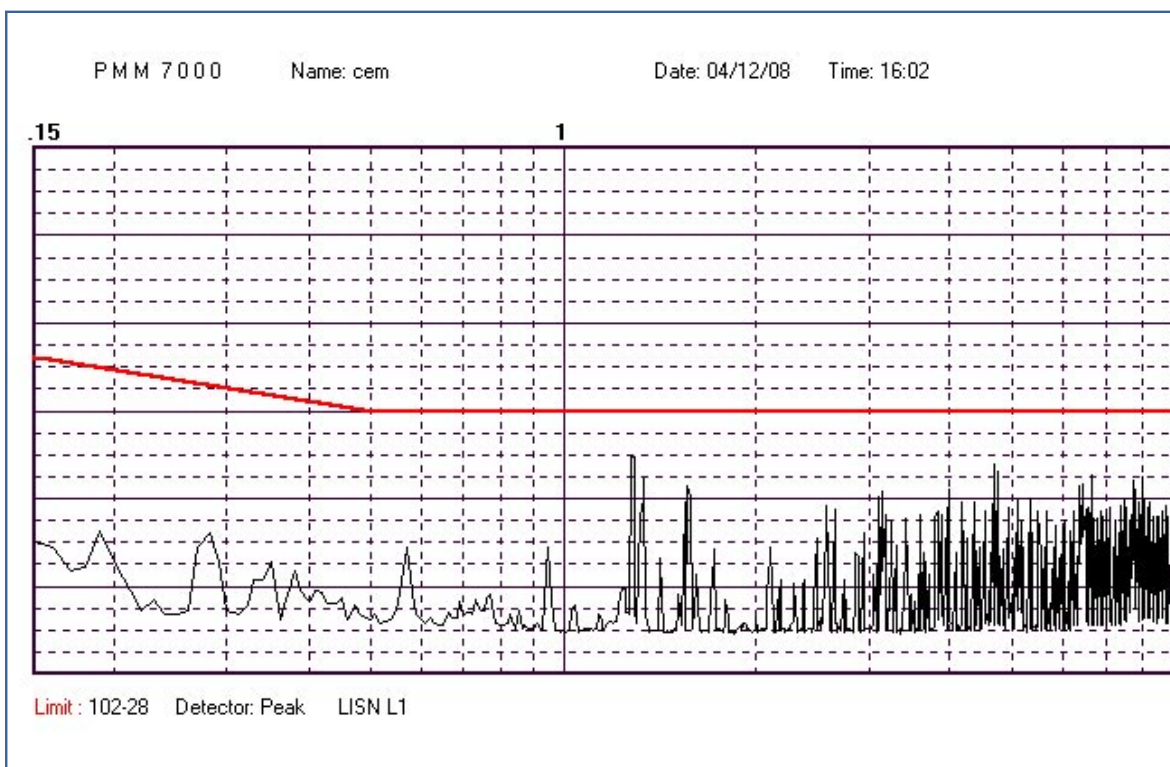

Emission measurement for PST2428-12120-12120-NN

Immunity to Environmental Conditions

Test method	Standard	Test conditions	Status
Humidity	MIL STD 810D Proc. 507-2	Humidity 93 %, 40°C, 56 days	Conformal coating (V) option only, built to meet
Shock	MIL STD 810D Proc.516.3	40G	Built to meet
Altitude	MIL-STD-810F	Method 500.4, 40000ft and 70000ft, operational	Built to meet
Vibrations	MIL STD 810D Proc. 514-3	Proc 1, cat.14	Built to meet



▼ Mechanical data

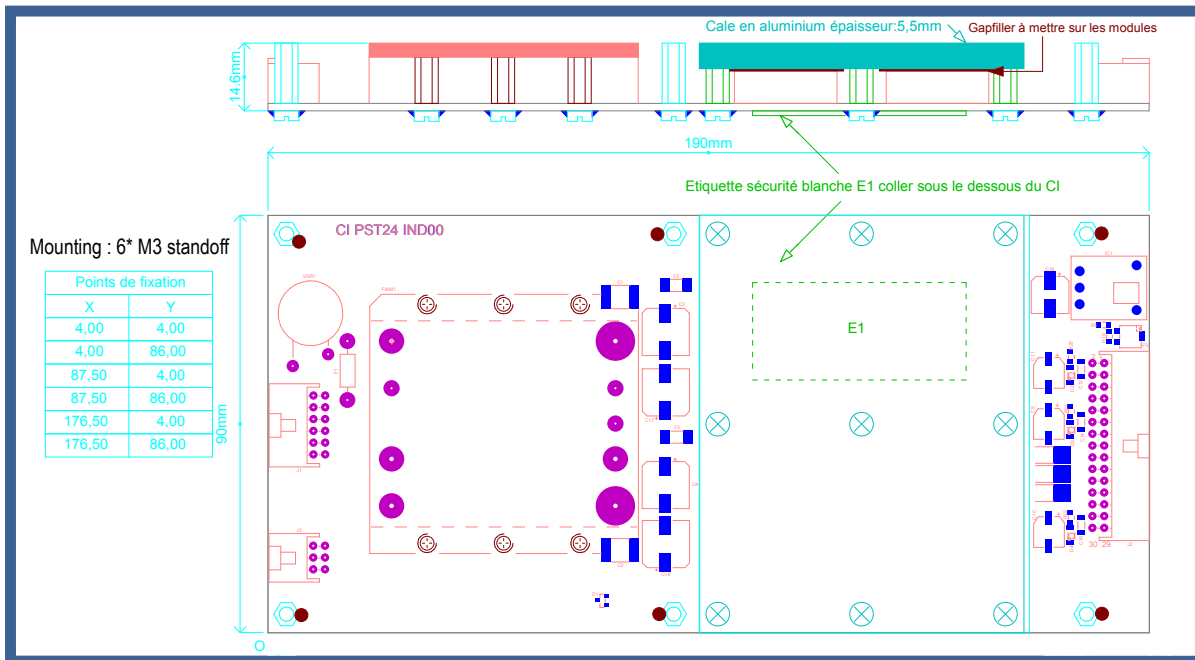

H option

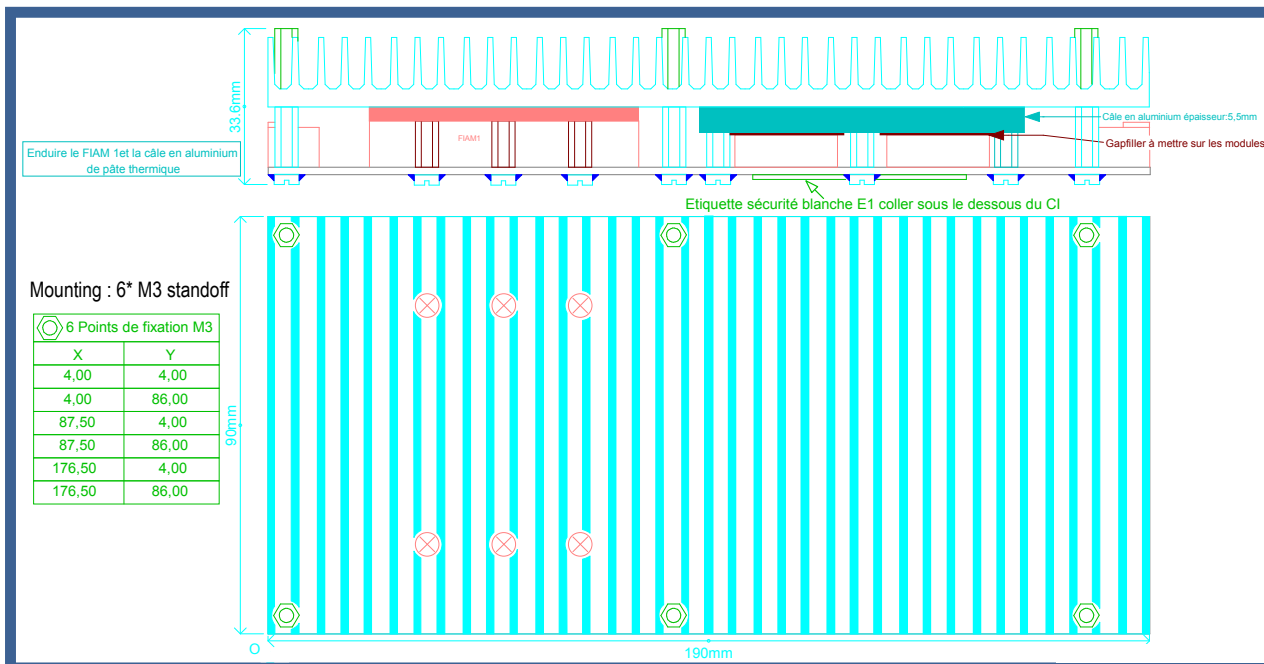



▼ Safety and Installations Instructions

Connector Pin Allocation

INPUT : J1: Molex 90130-3212 (12pins, 3A / pin), J3: Molex 90130-3206 (6 pins)
 OUTPUT : J2: Molex 90130-3230 (30 pins, 3A / pin)

PIN	Description	
J1: 9 to 12	+IN	Positive input voltage
J1: 1 to 4	-IN	Negative input voltage
J1: 5 to 8	Earth	
J2:1	+V3	Positive Output voltage 3
J2: 2 to 6	0V1	Return Output voltage 1
J2: 7 to 15	+V1	Positive Output voltage 1
J2: 16 to 20	0V1	Return Output voltage 1
J2:21 to 25	+V2	Positive Output voltage 2
J2: 26 to 30	0V2	Return Output voltage 2
J3:1	-INH	- Inhibition
J3:2	+INH	+ Inhibition



Installations Instructions

These converters are components, intended exclusively for integration into other equipment by an industrial assembly process or by a professionally competent person. Installation must strictly follow the safety regulations in respect of the enclosure, mounting, creepage and clearance distances, markings of the end-use application.

Connection to the system shall be made via the corresponding mating connector .

The +IN is internally fused. This fuse is designed to protect the converter against overcurrent caused by a failure, but may not be able to satisfy all requirements. External fuses in the wiring circuit to one or both input pins may be necessary to ensure compliance with local requirements.

Do not open the converters, or the warranty will be invalidated. Make sure that there is sufficient heat dissipation available for conduction cooling. This should be verified by measuring the case of temperature at the specified measuring point, when the converter is operated in the end-use application.

Standards and Approvals

The converters are built to meet the safety standards IEC 60950-1, EN 60950-1, UL 60950-1 and CSA 60950-1.

Cleaning Agents and Process

The converters are not hermetically sealed. In order to avoid possible damage, any penetration of liquids shall be avoided.

Isolation

The electric strength test is performed in the factory in accordance with IEC/EN 60950.



Electric Strength

Characteristic		Input to Earth	Input to Output	Output to Earth	Output to Output	Unit
Electric strength	Design strength	1500	1500	500	N/A	Vrms
	Factory test for production units (>10s)	1000	1000	500	N/A	Vdc
Insulation resistance				> 100	N/A	Mohms

Temperatures

Conditions		Standard			T option			Unit
		Min.	Typ.	Max.	Min.	Typ.	Max.	
Ambiant	Operating	-40		+85	-55		+85	°C
Baseplate		-40		+100	-55		+100	
Storage	Not operating	-40		+125	-65		+125	

Reliability

MIL-HDBK-217F, notice 2	Model	Baseplate Temp.	GB	NS
MTBF (Hours)	PST2428	40°C	1108189	191000
		70°C	642749	110900
		100°C	404268	68761

Options and configurations

Pout max : 240W

IN max : see table page 2

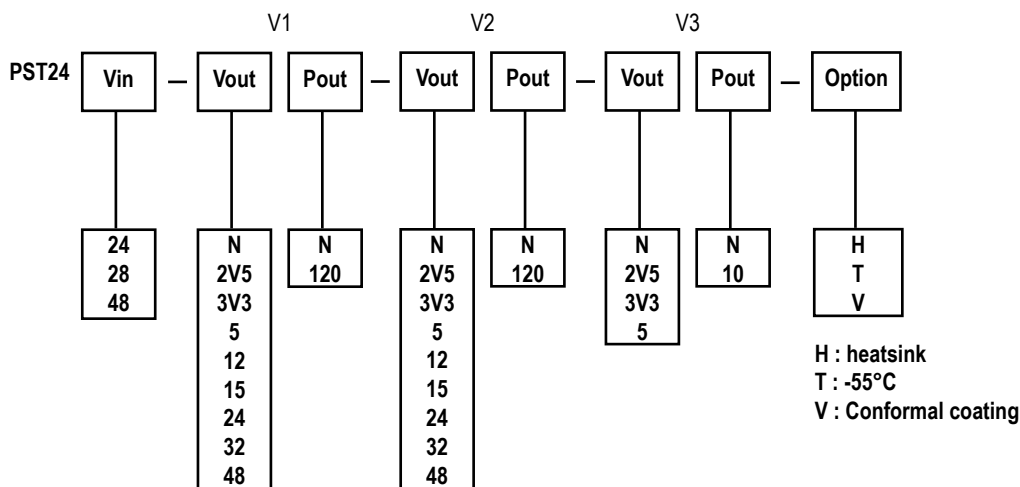

Note: For intermediary voltage (13,2Vdc for example), please specify 13V2 in corresponding output of the part number to receive the converter adjusted and tested at this voltage in our factory.