



FEATURES

3U x 8TE x 160 mm
 INPUT : 180 - 264 Vac (90-264 Vac consult factory)
 OUTPUT : up to 160W
 1-3 outputs
 Efficiency : 73 % typ.

APPLICATIONS

Industrial

INPUT

Voltage range : 180 - 264Vac
 Nominal : 230 Vac
 Input protection : fuse
 transient and surges protected

OUTPUT

Voltage : V1 : 3V3, 5V, 12V, 15V, 24V, 28V, 48Vdc from 25 to 75W
 V2 : 12V, 15V, 24V, 28V, 48Vdc from 25 to 75W
 V3 : -5V/2A, -12V/1,5A, -15V/1,5A, -24V/0,8A (*)

(*) Need output 2 to have output 3

	OUTPUT		Conditions
	Typ.	Max.	
Line regulation	0,02 %	0,2 %	Low line to high line ; full load
Load regulation	0,02 %	0,5 %	No load to full load
Ripple and noise	1 %	2 %	Peak to peak, nom. Input ; full load
Current limit		115 % of I nom.	Vout = 95% of nominal ; Automatic restart
Short circuit current protection	115 % of I nom.	140 % of I nom.	Automatic restart

SIGNALS

Default : Led, when | heatsink temperature > 90°C
| output overvoltage

Output OK : Led on every output

ENVIRONMENTAL

Storage temperature : -25°C to +100°C

Operating temperature : -10°C to 70°C ambient, forced air, nominal power
derating 2,5% / °C above 50°C

ISOLATION

Input to chassis : 1500 Vrms or 2121 Vdc

Input to Output : 3000 Vrms or 4242 Vdc

Output to Chassis : >100 Mohms at 500 Vdc

GENERAL

Safety : built to meet EN60950

EMI : built to meet EN55022, conducted.

MECHANICALS

DIN41612 F form 48pts



DIN41612 F FORM 48pts CONNECTOR

PIN	d	b	z
2	NC	NC	NC
4	NC	NC	NC
6	NC	NC	NC
8	0V	0V	0V
10	-V3	-V3	-V3
12	+V2	+V2	+V2
14	+V1	+V1	+V1
16	0V	0V	0V
18	0V	0V	0V
20	0V	0V	0V
22	NC	NC	NC
24	NC	NC	AC/N
26	NC	AC/N	NC
28	NC	NC	AC/L
30	NC	AC/L	NC
32	NC	NC	Ground

HOW TO ORDER ?

Just fill in.

Pmax : 160W

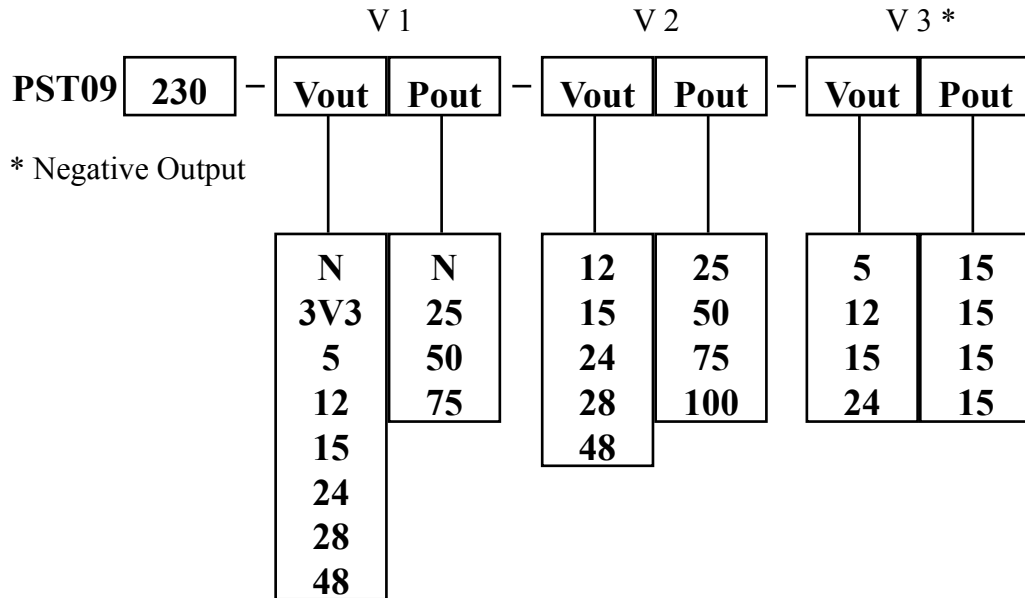

COMPANY NAME :

ADDRESS :

NAME :

JOB TITLE :

QUANTITY :

DELIVERY DATE :

INFORMATION :

SEND TO :

POWER SYSTEM TECHNOLOGY
19, 21 rue Gustave Eiffel - Bâtiment A2
28630 GELLAINVILLE - FRANCE
Tel. : +33 (0) 2 37 30 78 40 - Fax : +33 (0) 2 37 30 77 71
Email : sales@powersystemtechnology.com